

Metal shed/Metalen tuinhuis/Abri en metal

Owner's manual / Handleiding / Manuel

- ⓔ Assembly instructions for Archer C
- Ⓝ Montage instructies voor Archer C
- ⓕ Instructions de montage pour Archer C

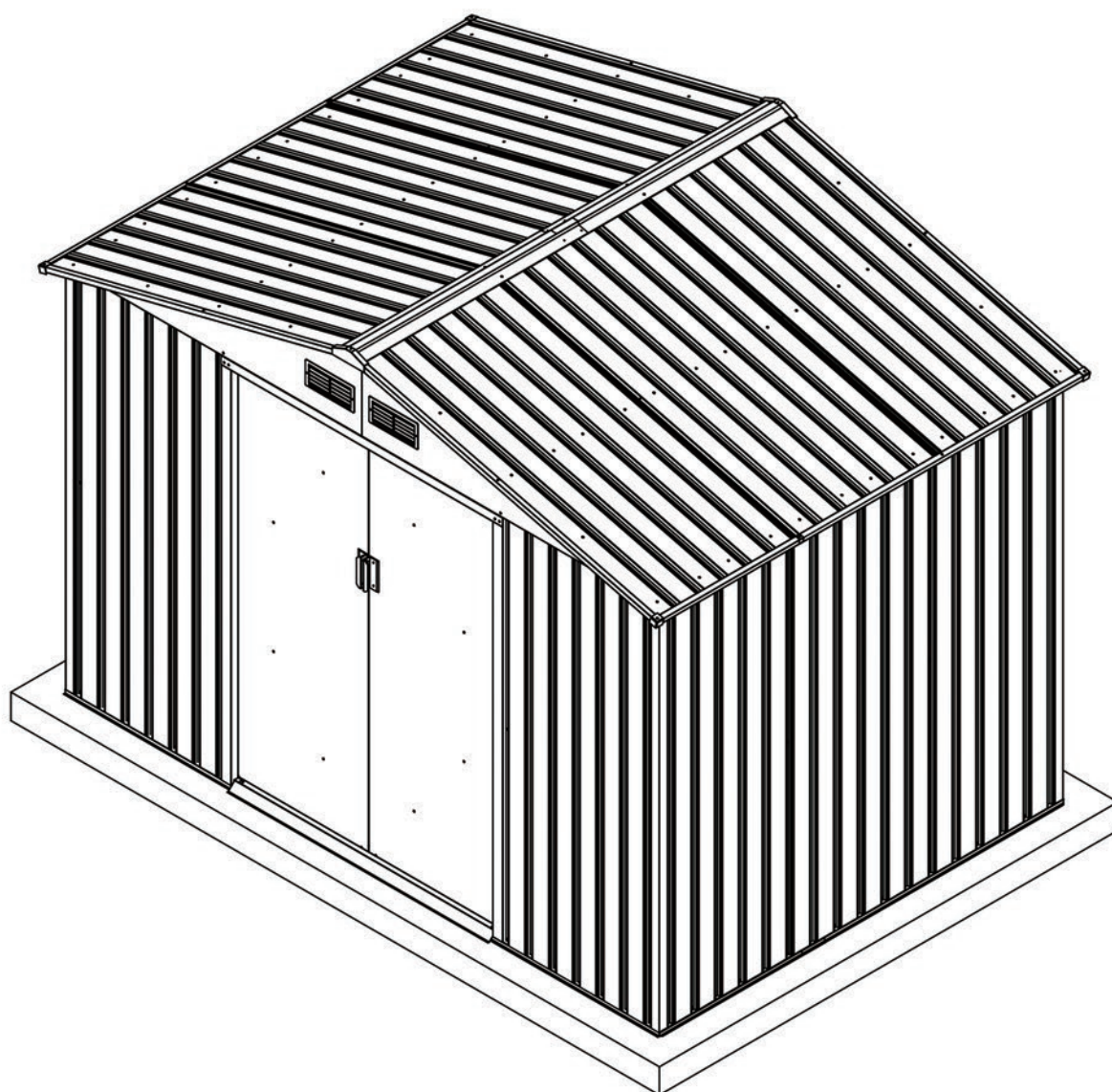

-
- ⓔ Requires 2 people and takes 3-4 hours for installation.
 - Ⓝ 2 personen zijn nodig voor de montage, die 3-4 uur in beslag zal nemen.
 - ⓕ 2 personnes sont nécessaires pour le montage, qui prendra 3-4 heures.

Assembly Preparation

Please check local building codes regarding footings, location and other requirements before beginning construction.

Assembly instructions:

Reviewing all instructions and the appropriate information before you begin, make sure following the step sequence carefully for successful results.

Flooring base:

A good location for the storage building is a square and level area with good drainage. The base is not included in the kit which may need purchase separately or may construct a foundation and anchoring system of your own. The foundation base should be 10 cm larger than the base rail of the shed (minimum 10cm thickness concrete slab is recommended).

A strong plastic sheet (thickness: at least 150µm) should be placed under the foundation to assist in reducing rising dampness from the soil, thus reducing condensation build up in the shed. Your storage building must be anchored to prevent wind damage. Once secured, it is highly recommended applying silicone along the inside of the base rail to minimize condensation.

Parts and Parts List:

Before you start, check to be sure that you have all the necessary parts for your building (refer to the Parts List Page). If you find that a part is missing, please notify the seller within 7 days after receiving the product. Do not attempt to assemble the building if parts are missing because any building left partially assembled may be seriously damaged by light winds.

Please tear off the protection layer before assembly, keep the part number label if needed.

Tools you need:

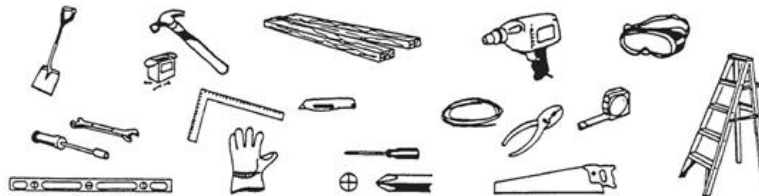

Safety must be put in the No. 1 position:

1. Select a dry and calm day for your assembly. Team works (Two or more people) are required during the assembly. It is also recommended to finish the assembly in a day to avoid damage to the product or missing of some small parts. Keep all small parts (screws etc.) in a bowl so they do not get lost.
2. Wearing safety gloves, eye protection and long sleeves during the assembly to prevent injury. Pay attention to the sharp edge of some parts.
3. Children and pets are not allowed entering into the construction site.
4. Never concentrate your total weight on the roof of the building.
When using a step ladder make sure that it is safe.

Care & Maintenance:

1. Keep the shed clean with soft cloth, use water if necessary.
2. Keep the door tracks clear of dirt and other stuff that prevent them from sliding easily.
3. Clean the snow with necessary tools to make sure it is safe to enter into.
4. The shed is not made for living but storing stuff.
5. Please add some oil on the top & bottom door sliding channel to make door slides smoothly.

Handleiding

Gelieve u te informeren bij uw gemeente voor de bouwvoorschriften vooraleer u aan de montage begint. Lees en begrijp de instructies en voorschriften die vermeld worden in deze handleiding, zodat de montage gemakkelijk en aangenaam verloopt.

Montage instructies:

Vooraleer u begint met de montage, vragen wij u de handleiding grondig te lezen en het stappenplan goed te volgen, zodat de montage correct verloopt.

Vloer/chape :

Een goede locatie voor de berging, is een vierkantig en recht platform met een goede drainage.

De basis is niet meegeleverd in het pakket, waardoor het misschien nodig zal zijn om er ééntje aan te schaffen of zelf te maken.

Er dient een plastieken bache (dikte : 150µm) geplaatst te worden onder de fundering. Dit zal ervoor zorgen dat er minder vocht uit de grond komt en minder condensatie in de berging zal ontstaan.

De berging dient vast gemaakt te worden, om schade te voorkomen bij felle wind.

Eénmaal vast gemaakt, is het aangeraden om silicone te spuiten rond de onderste profielen aan de binnenkant van de berging, dit om condensatie te minimaliseren.

Onderdelen en onderdelenlijst :

Vooraleer u begint, dient u alle onderdelen uit elkaar te halen en deze te identificeren, zodat u er zeker van bent dat u alle nodige onderdelen bezit.

Indien u onderdelen ontbreekt, dient u de verkoper te informeren binnen 1 week na ontvangst van het product. Probeer de berging niet te monteren als er onderdelen ontbreken, want een berging die niet af is, kan beschadigd geraken of schade veroorzaken bij wind.

Benodigdheden:

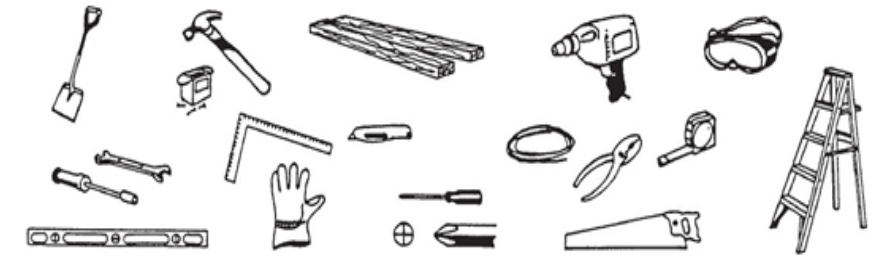

Veiligheid moet op de eerste plaats komen:

1. Kies een droge en rustige dag (zonder te veel wind) voor de montage. U dient met minstens 2 personen te zijn en het wordt aangeraden om de montage de dag zelf te beëindigen om schade en/of het verlies van onderdelen te voorkomen.
2. Draag veiligheidshandschoenen, een veiligheidsbril en lange mouwen tijdens de montage om te voorkomen dat u zich bezeert. Wees voorzichtig met de scherpe randen.
3. Kinderen en huisdieren dienen niet op de plaats van de montage aanwezig te zijn.
4. Plaats uw volledig gewicht nooit op het dak van de berging. Wees voorzichtig bij het gebruik van een trapladder.

Onderhoud :

1. Hou de berging proper met een zachte doek, gebruik water indien nodig.
2. Hou de deurrails proper, zodat de deuren gemakkelijk schuiven.
3. Verwijder sneeuw van het dak en zorg ervoor dat het veilig is om de berging te betreden.
4. De berging dient niet als woning, maar om materiaal in op te bergen.
5. Voeg wat olie toe aan de boven-en onderkant van de schuifdeuren, zodat deze goed kunnen schuiven.

Manuel d'utilisateur

Veillez vous informer en ce qui concerne la fondation, l'emplacement etc. auprès de votre commune avant de démarrer la construction. Lisez et comprenez les instructions et les précautions mentionnées dans ce manuel, pour que le montage soit plus facile et agréable.

Instructions d'installation :

Avant de commencer le montage, nous vous prions de bien lire les instructions d'installation, tout en respectant les étapes unes à unes, afin que le montage soit correcte.

Base / Sol :

L'abri doit être installé sur une fondation carrée et droite, avec un bon drainage.

Le sol n'est pas compris dans ce kit, ce qui nécessitera peut être à en acheter ou d'en construire un soi-même.

Une bâche en plastique (épaisseur : au moins 150µm) doit être placée sous la fondation pour réduire l'humidité provenant du sol et ainsi réduire la condensation dans votre abris.

L'abris doit être encre au sol pour éviter qu'il ne s'envole quand il y a beaucoup de vent.

Une fois encre au sol, il est conseillé de silconer l'intérieur de l'abris au niveau du sol.

Ceci pour réduire la condensation au minimum.

Liste des pièces et accessoires :

Avant de commencer, trie et identifiez toutes les pièces et les accessoires, pour être sûr d'avoir tout ce qu'il vous faut pour le montage de l'abris.

S'il vous manque une pièce, veuillez prendre contact avec le vendeur dans les 7 jours dès la livraison de votre abris. N'essayez pas de monter l'abris s'il vous manque des pièces, car une construction non terminée pourrait créer des dégâts avec le vent.

Les ustensiles dont vous avez besoin :

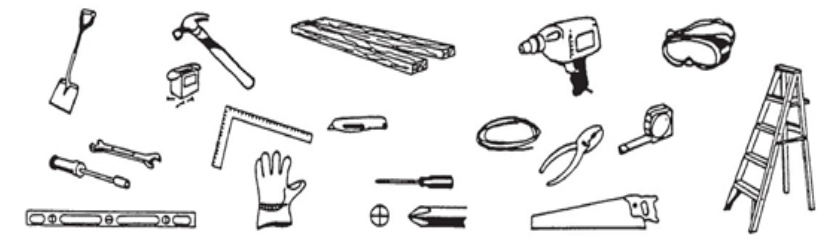

La sécurité doit être prioritaire :

1. Choisissez un jour sec et sans vent pour l'assemblage. Le montage doit se faire à minimum 2 personnes. Il est recommandé de terminer l'assemblage dans la journée, ceci pour éviter de perdre de petites pièces etc.
2. Mettez des gants de protection, des lunettes de protection et de longues manches pour éviter de vous blesser. Faites attention au bords, ils coupent.
3. Des enfants et animaux de compagnie ne sont pas autorisés à l'endroit où vous construisez.
4. Ne mettez jamais tout votre poids sur un seul point du toit de la construction.
Quand vous utilisez une échelle, faites en sorte que ce soit sécurisé.

Entretien :

1. Gardez l'abris propre à l'aide d'un chiffon et de l'eau propre si nécessaire.
2. Gardez le rail de la porte propre & évitez que des saletés de glissent dedans pour que la porte coulisse bien.
3. Retirez la neige du toit pour éviter des dégâts.
4. Cet abris est un endroit de stockage et ne peut être servi comme habitat.
5. Mettez un peu d'huile aux portes pour qu'elles coulissent bien.

- Ⓔ Size of Archer C
- Ⓗ Afmetingen van de Archer C
- Ⓕ Dimensions du Archer C

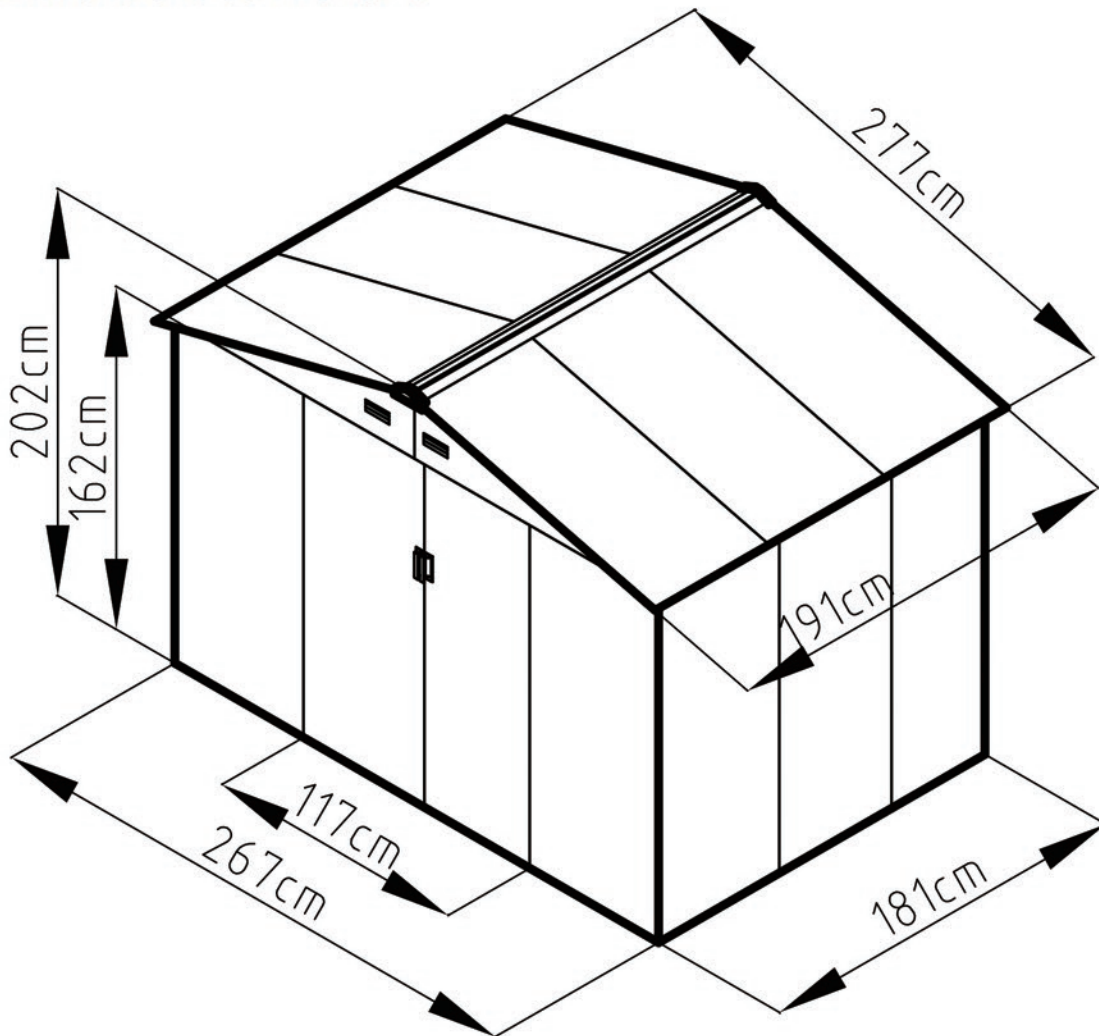

- Ⓔ Area of installation requirement
- Ⓗ Vereiste oppervlakte voor montage
- Ⓕ Surface nécessaire pour le montage

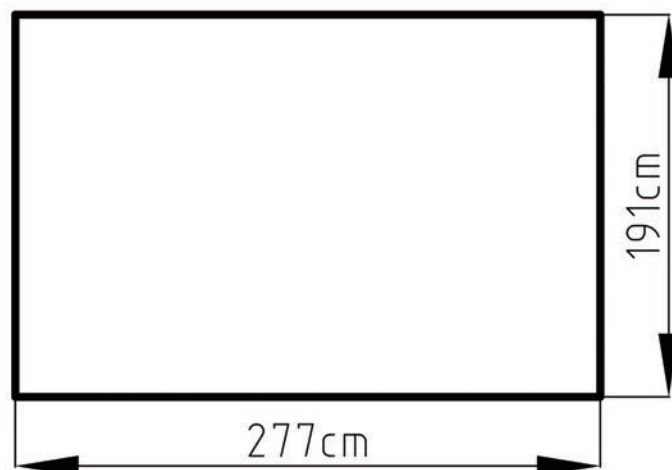

- (EN) Top 2
- (NL) Bovenkant 2
- (FR) Dessus 2

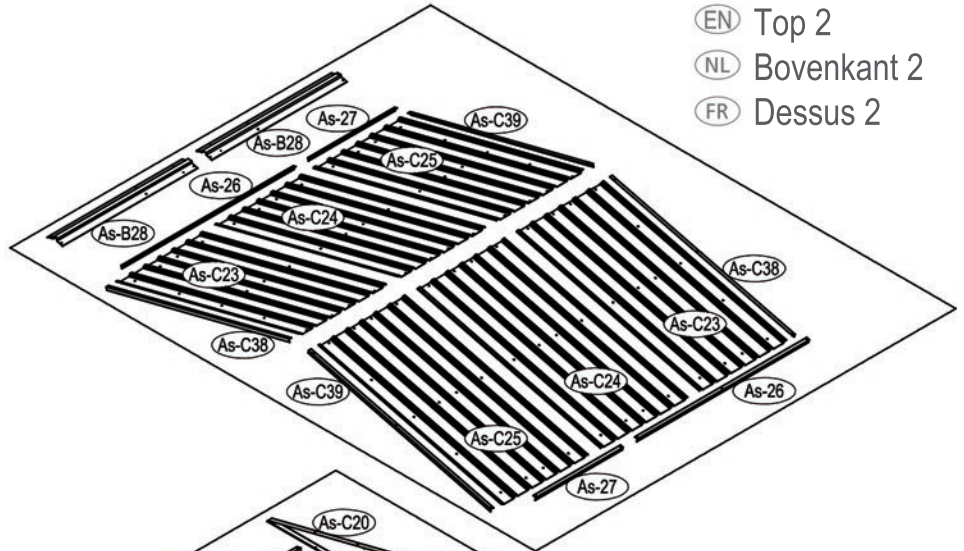

- (EN) Top 1
- (NL) Bovenkant 1
- (FR) Dessus 1

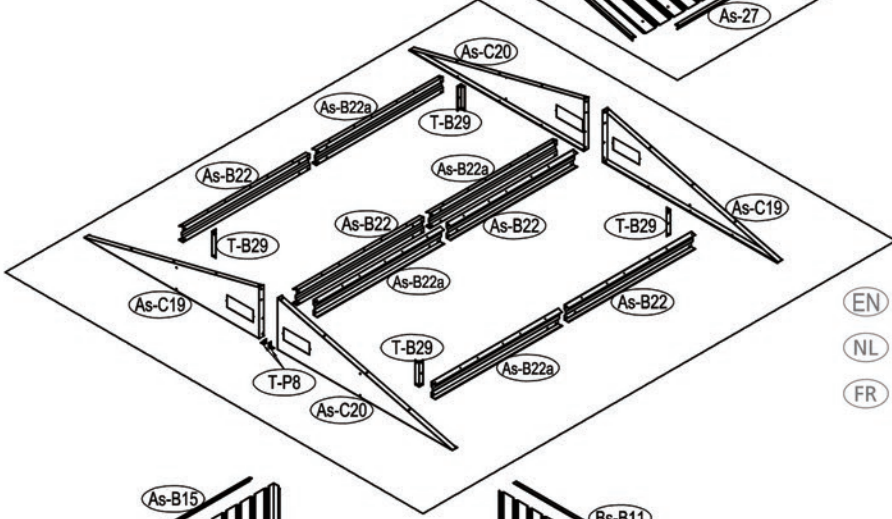

- (EN) Middle
- (NL) Midden
- (FR) Milieu

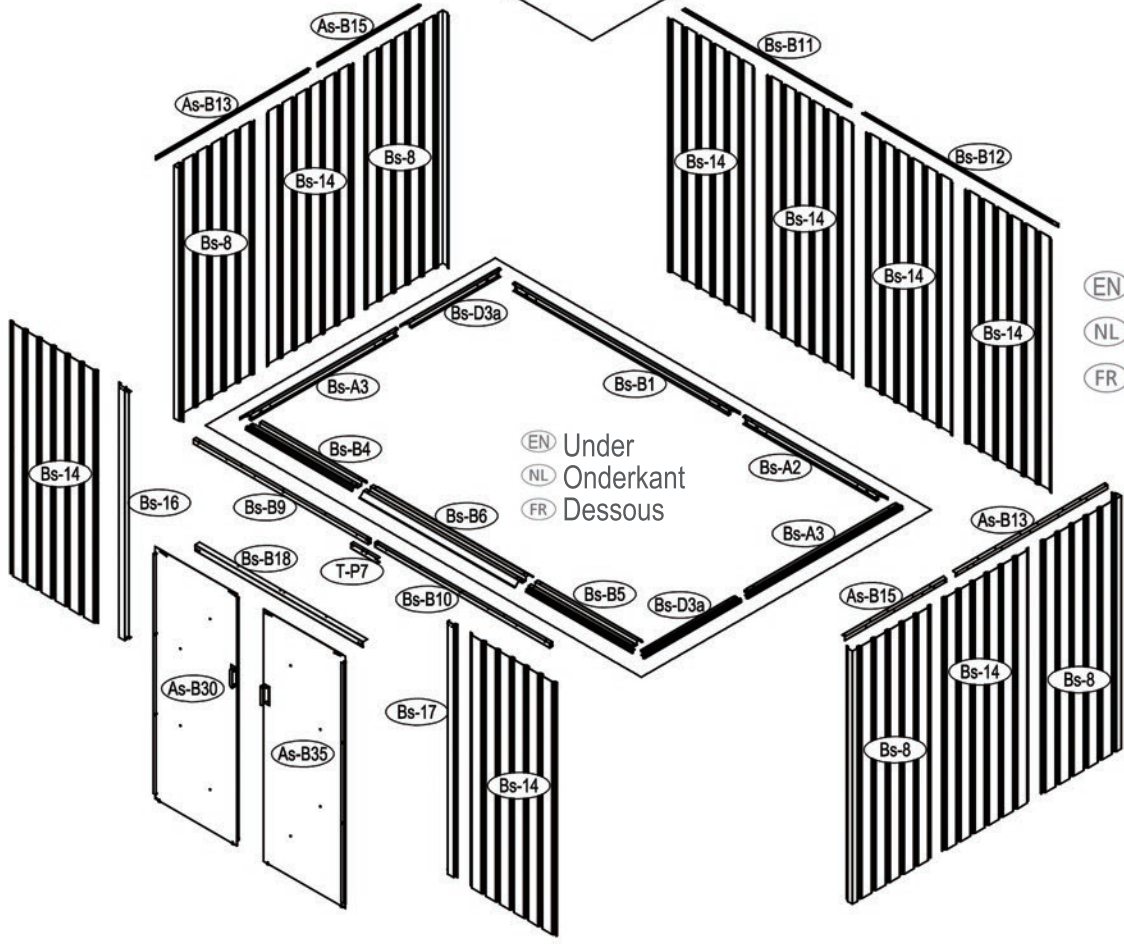

- (EN) Under
- (NL) Onderkant
- (FR) Dessous

No. /Nr.	Image/Afbeelding	mm	QTY/Aantal /Quantité	No. /Nr.	Image/Afbeelding	mm	QTY/Aantal /Quantité
Under / Onderkant / Dessous				Door / Deur / Porte			
Bs-B1		1693	x1	As-B30		1643	x1
Bs-A2		1074	x1	As-B35		1643	x1
Bs-A3		1174	x2	Ts-31		1583	x2
Bs-D3a		742	x2	Bs-B32		978	x4
Bs-B4		803	x1	Bs-B33		593	x1
Bs-B5		803	x1	Bs-B34		593	x1
Bs-B6		1170	x1	Bs-B36		593	x1
Middle / Midden / Milieu				Bs-B37		593	x1
Bs-8		1648	x4	Accessories			
Bs-14		1648	x8	T-P1			x4
Bs-B9		1315	x1	T-P2			x4
Bs-B10		1315	x1	T-P3			x4
Bs-B11		1249	x1	T-P4			x2
Bs-B12		1453	x1	TP5A			x4
As-B13		1145	x2	T-P6			x2
As-B15		762	x2	T-P7		200	x1
Bs-16		1648	x1	T-P8			x2
Bs-17		1648	x1	As-C40			x207
Bs-B18		1257	x1	As-C41		ST4X10	x240
Top 1 / Bovenkant 1 / Dessus 1				As-C42		ST4X16	x21
As-C19		1315.3	x2	As-C43		M4X10	x91
As-C20		1315.3	x2	As-C44			x79
As-B22		954.5	x4				
As-B22a		954.5	x4				
T-B29		160	x4				
Top 2 / Bovenkant 2 / Dessus 2							
As-C23		1420	x2				
As-C24		1420	x2				
As-C25		1420	x2				
As-26		1296	x2				
As-27		657	x2				
As-C38		1418	x2				
As-C39		1418	x2				
As-B28		1017	x2				

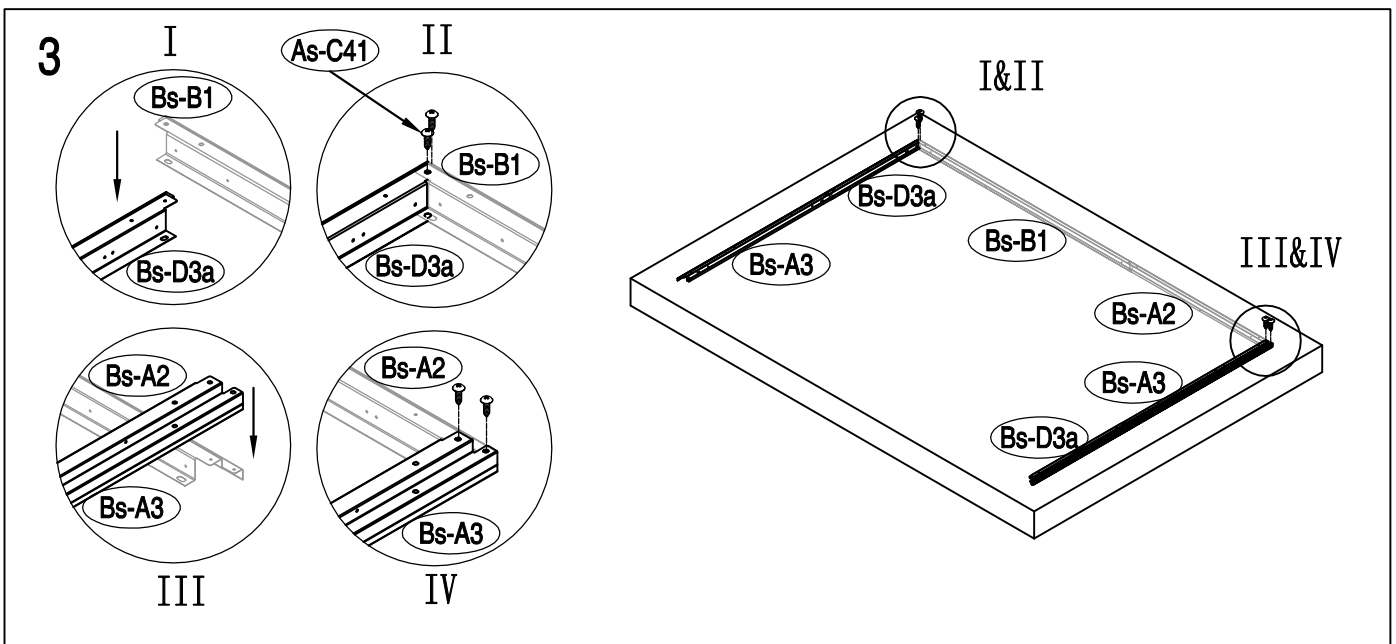
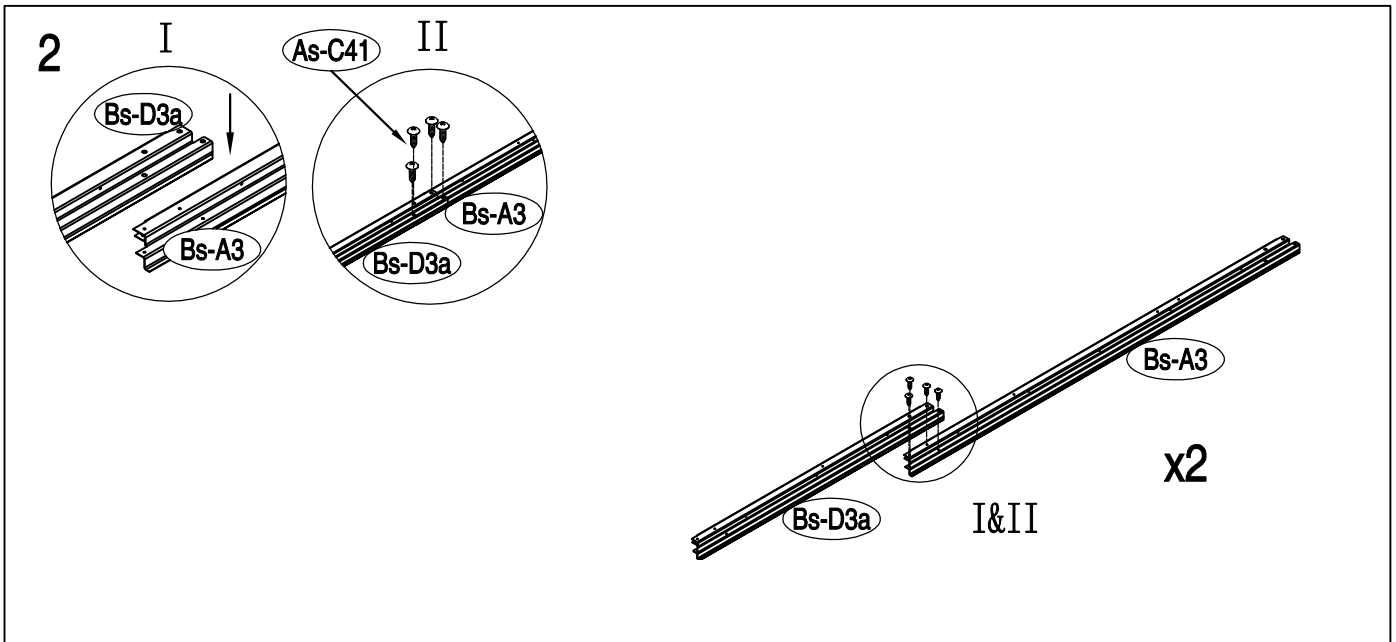
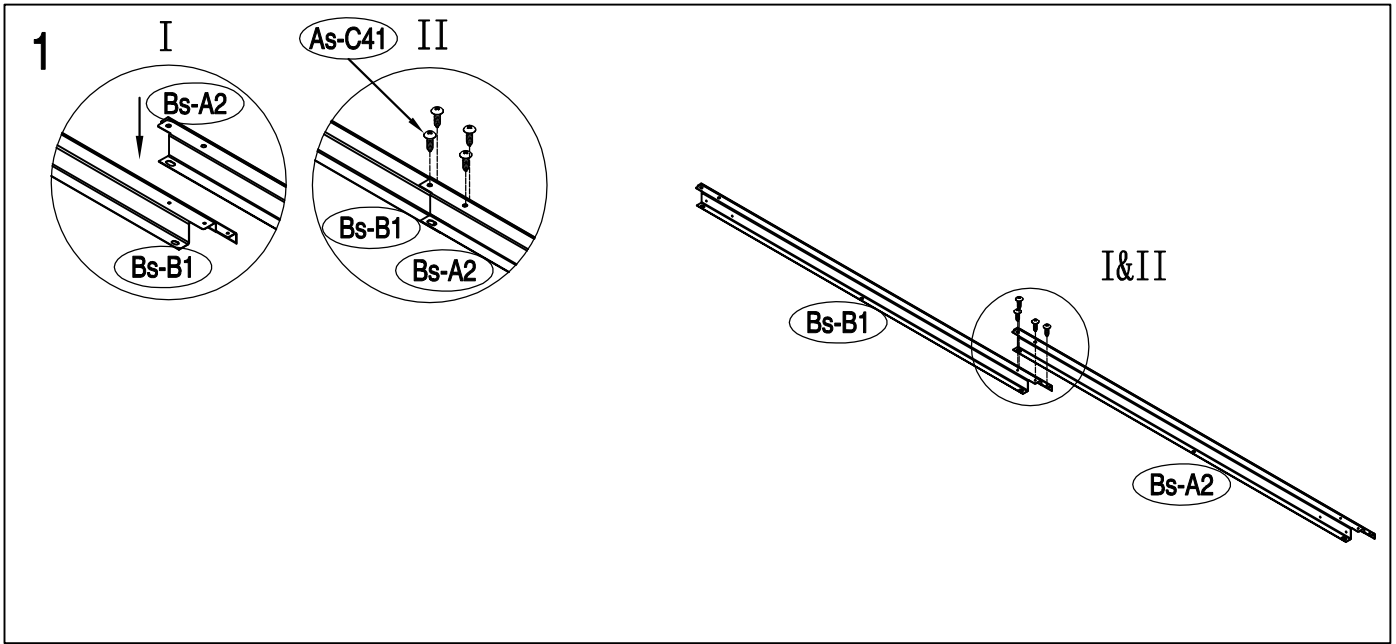

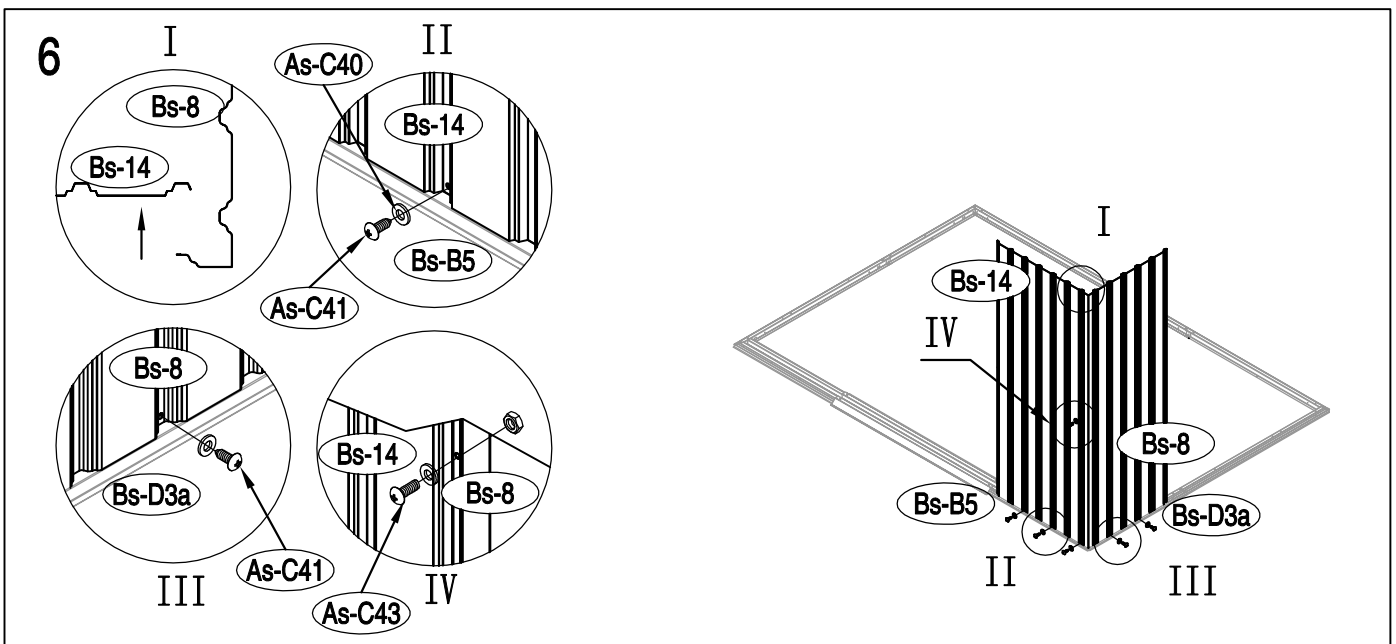
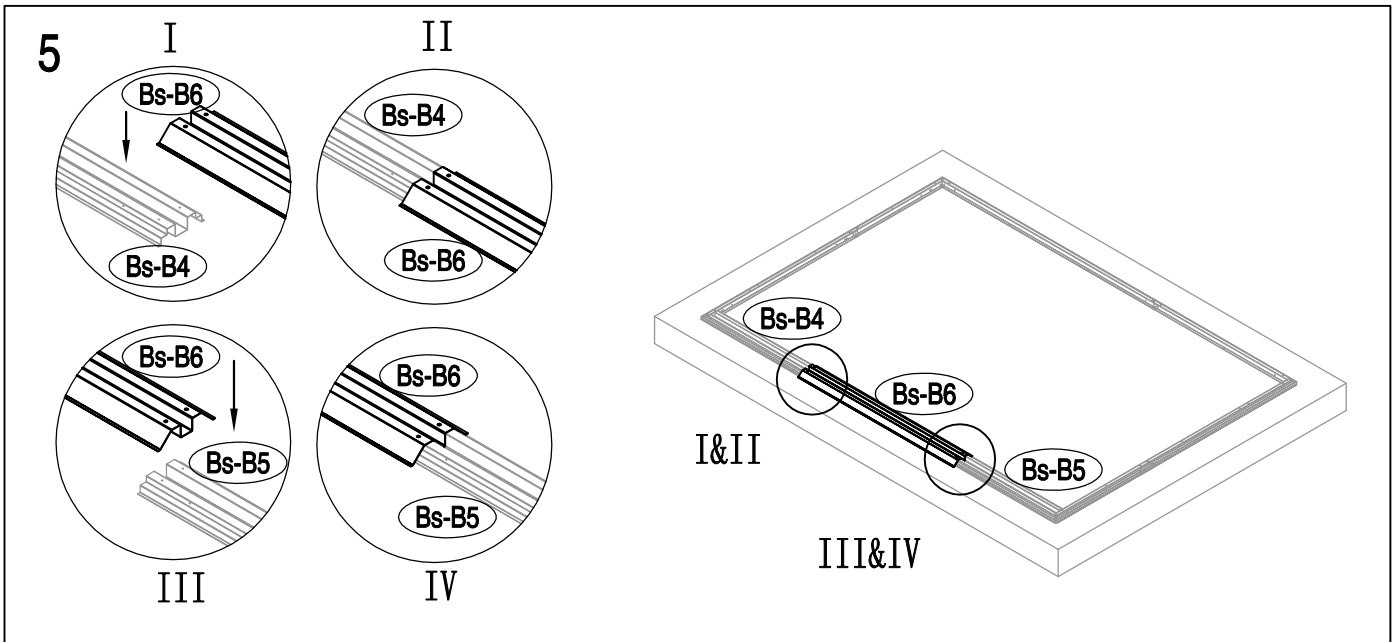
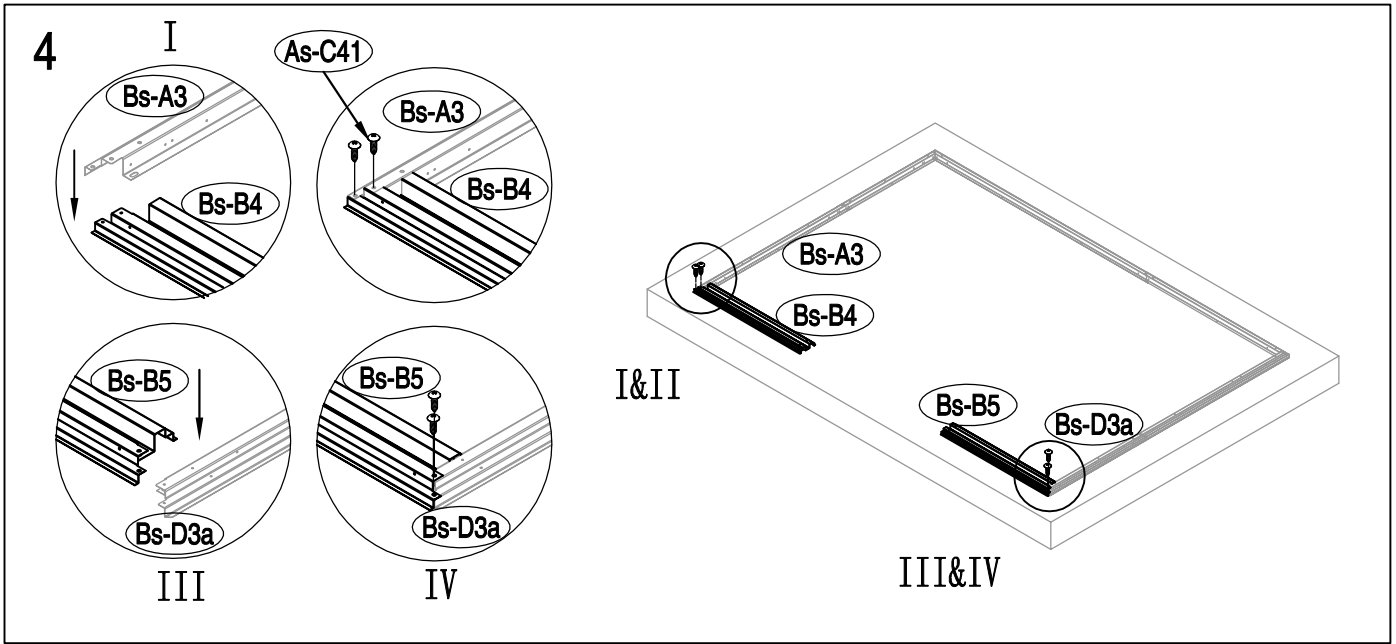

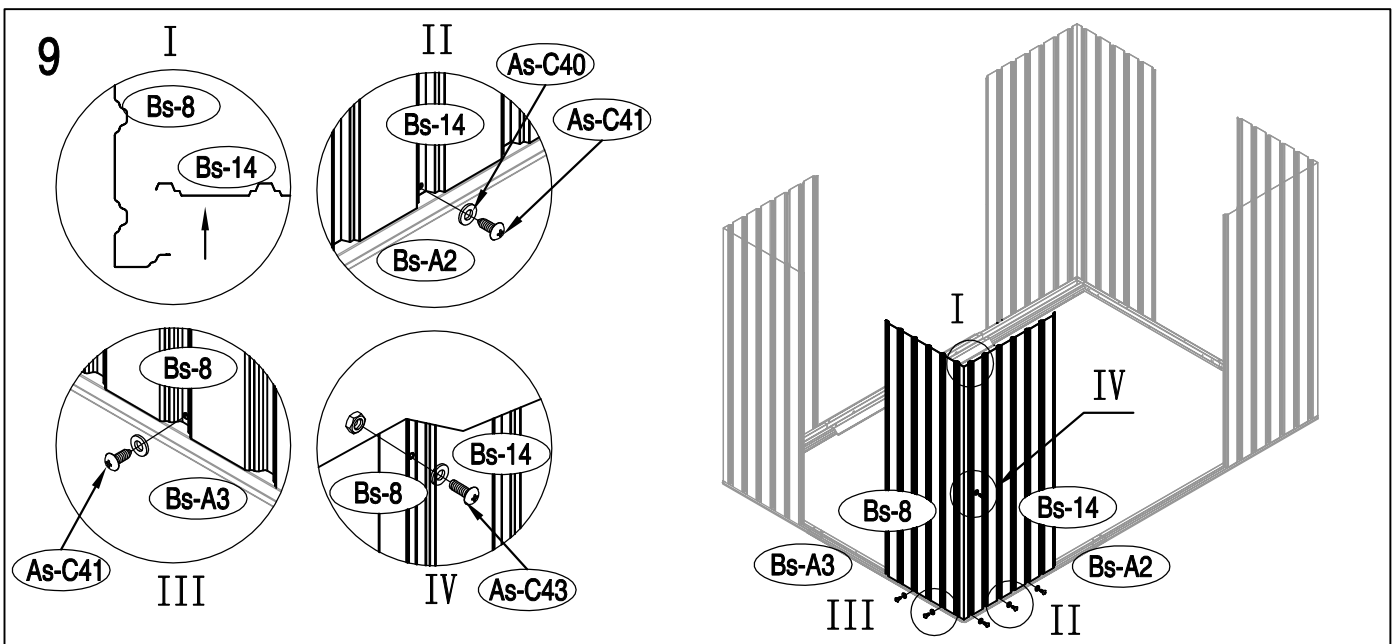
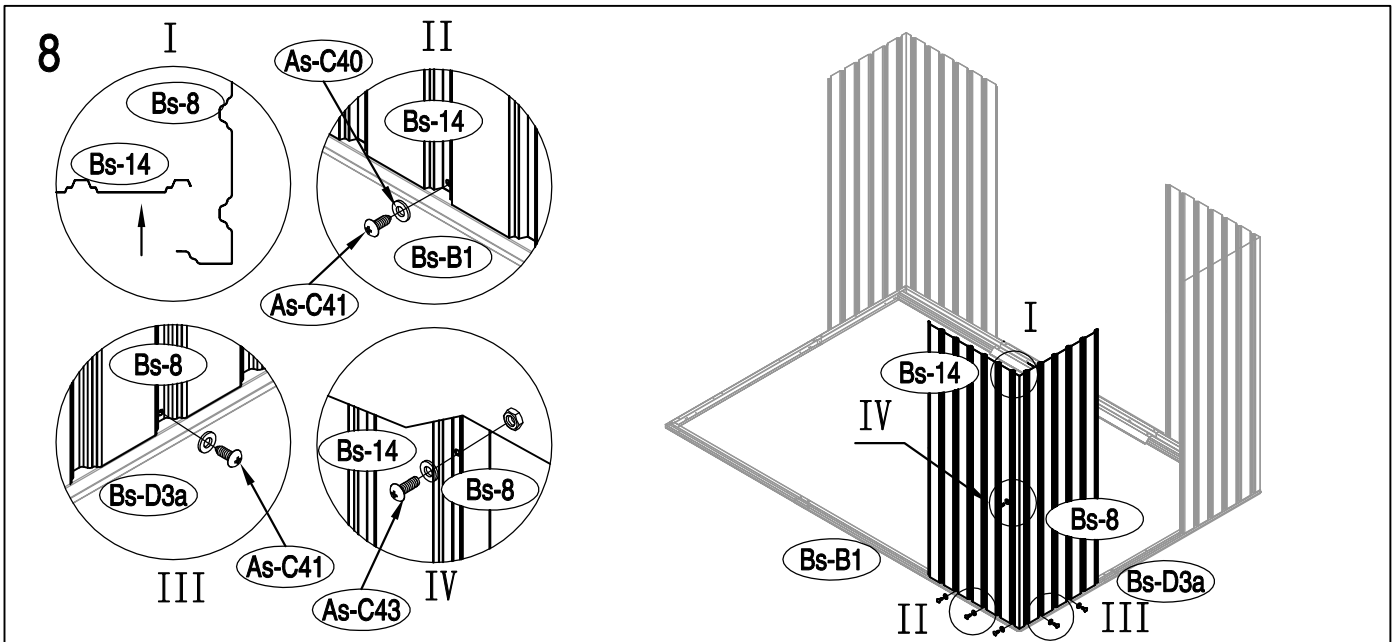
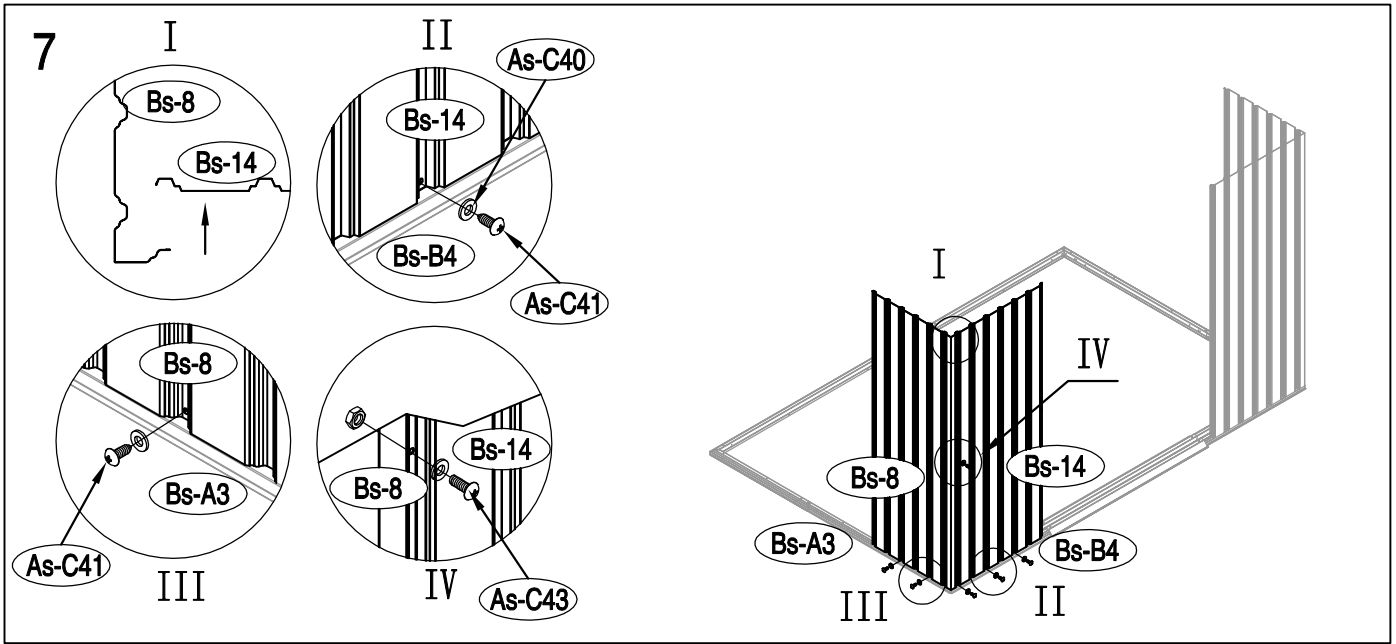

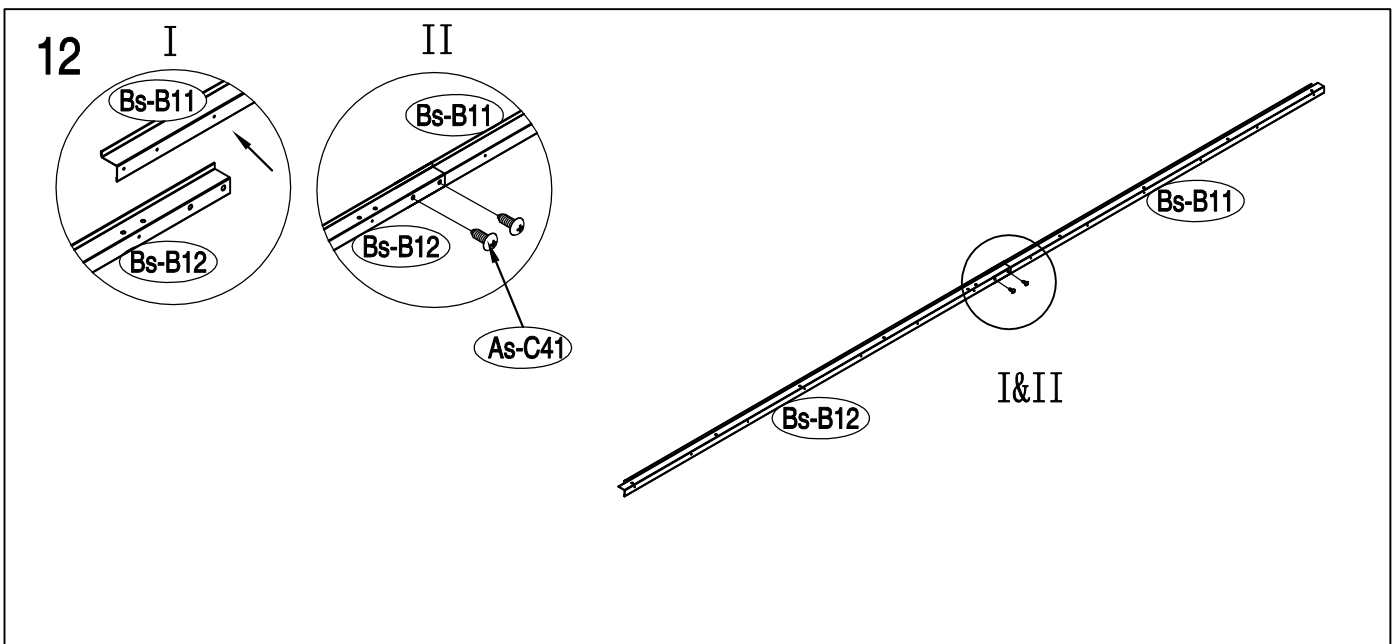
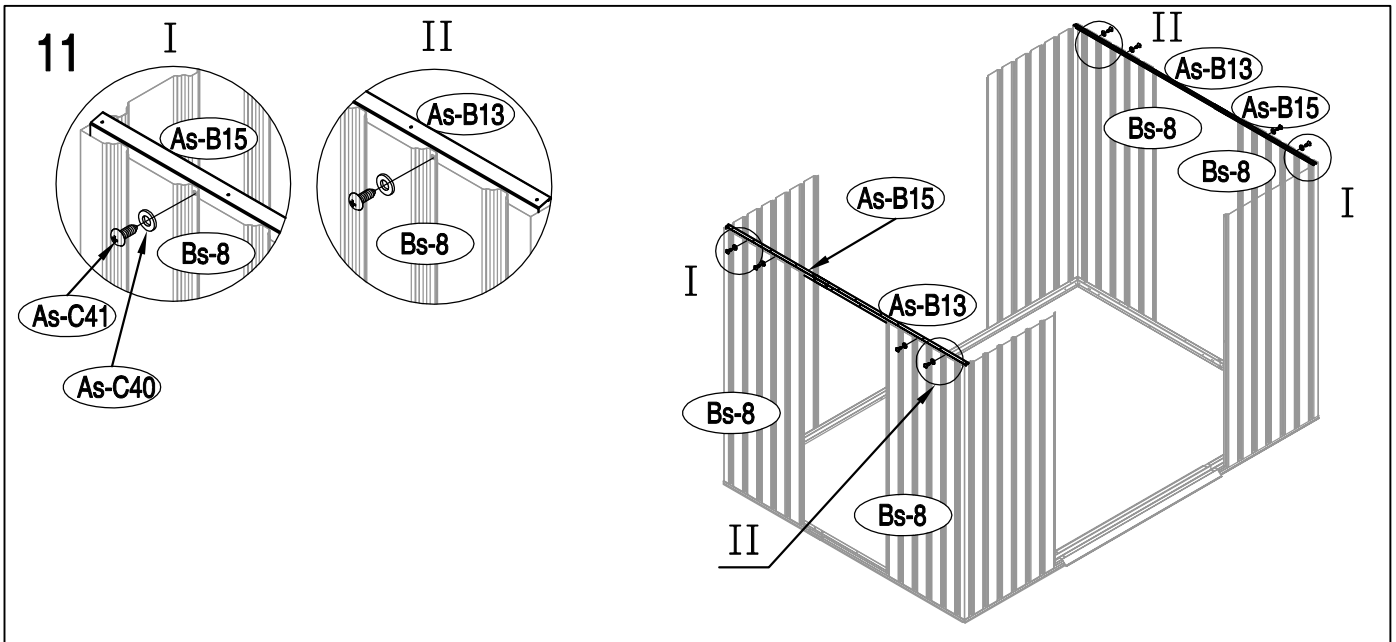
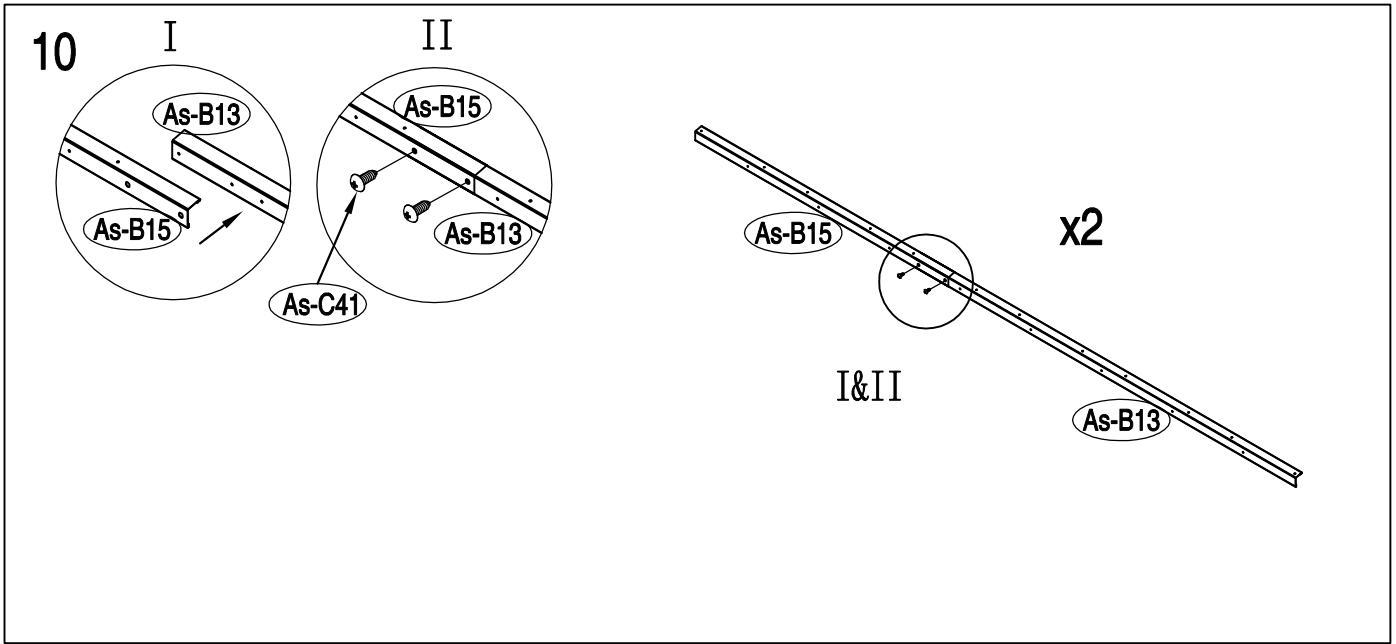

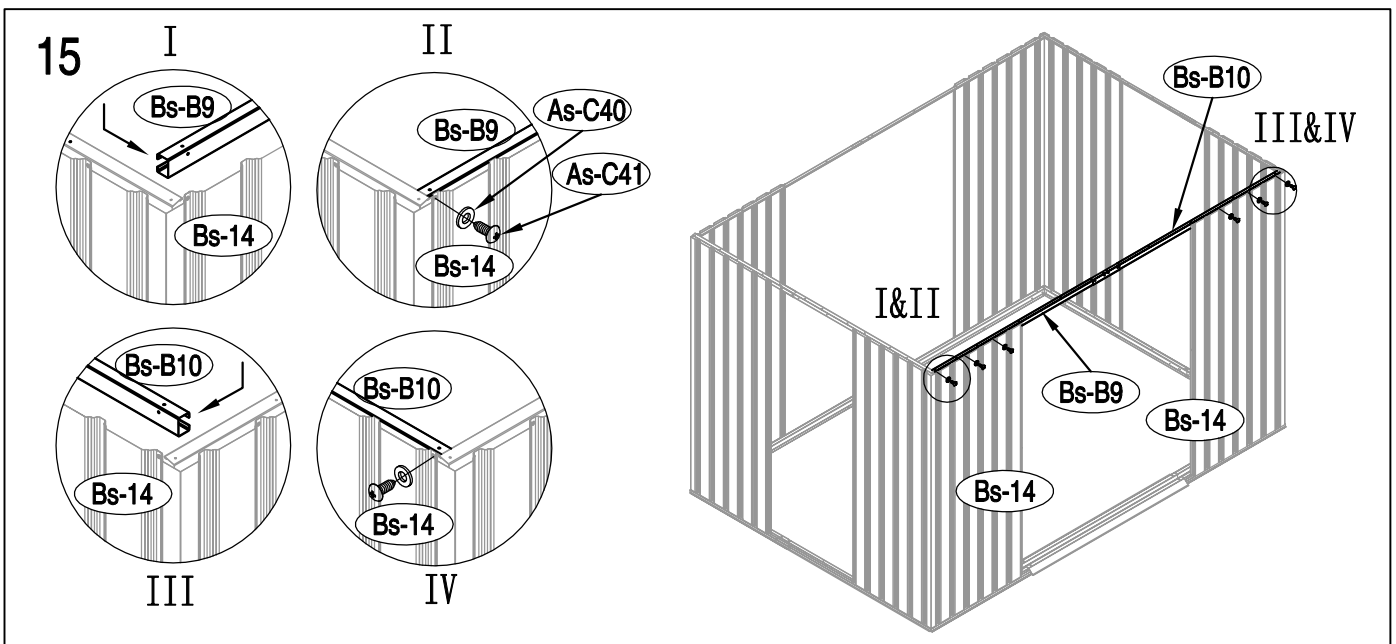
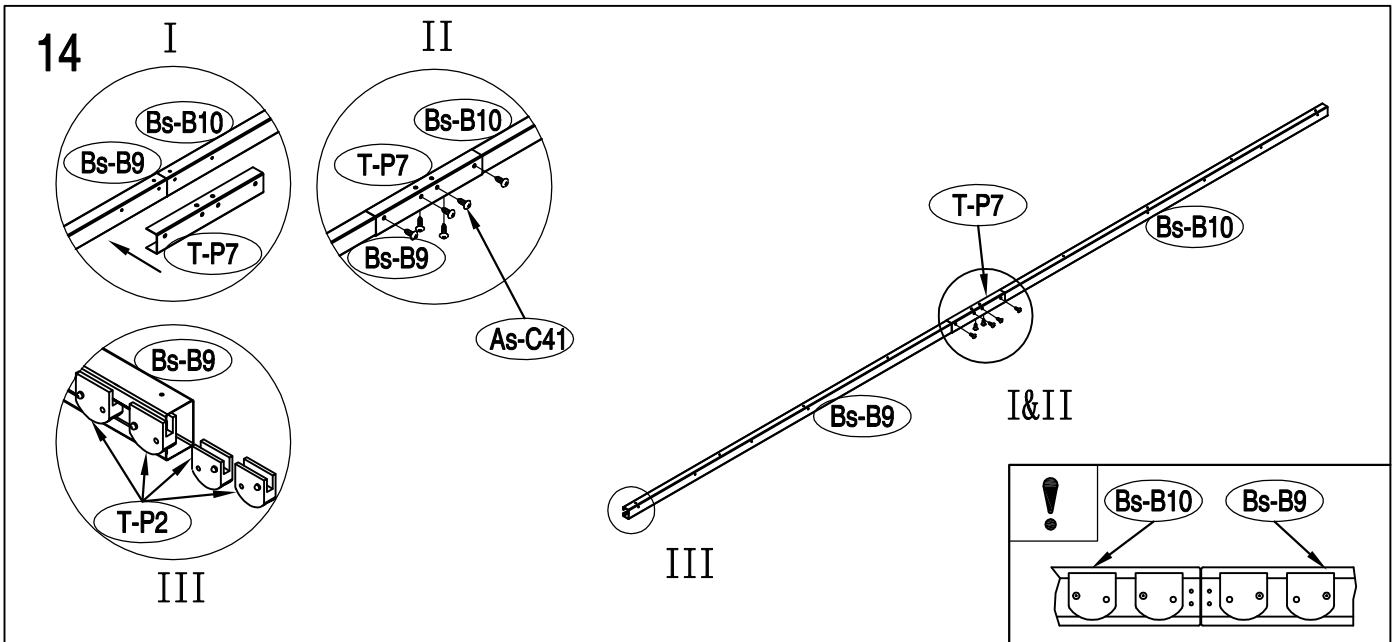
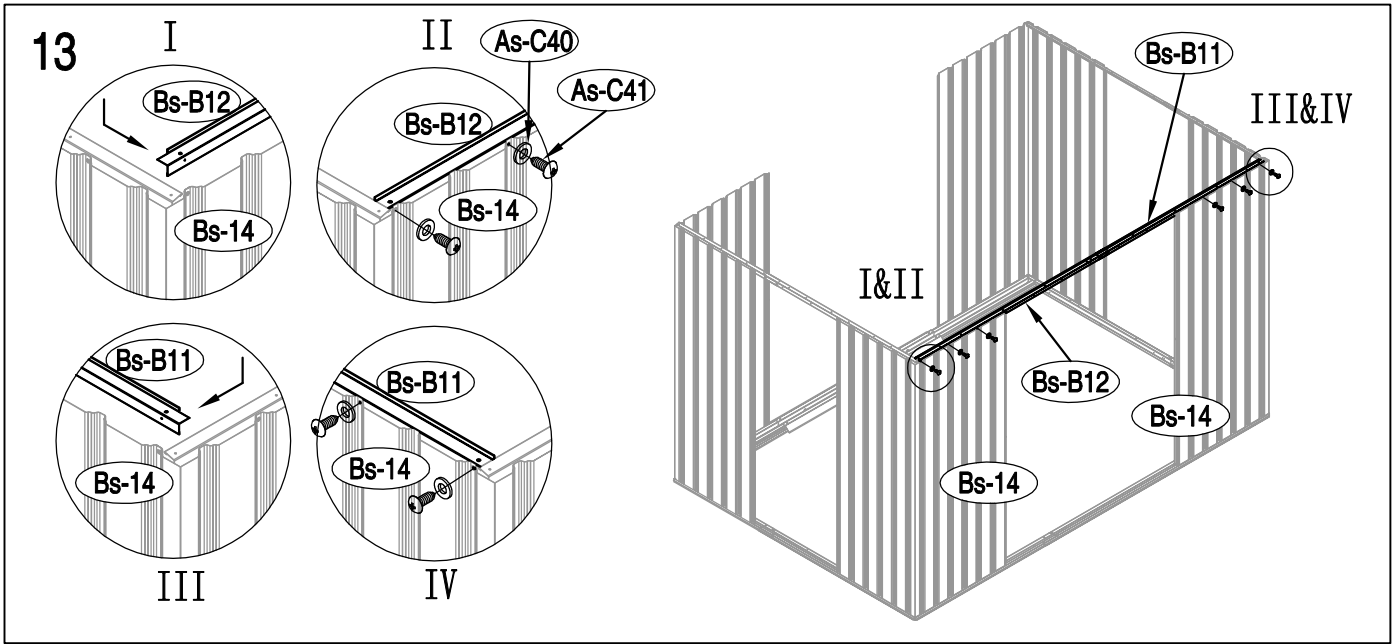

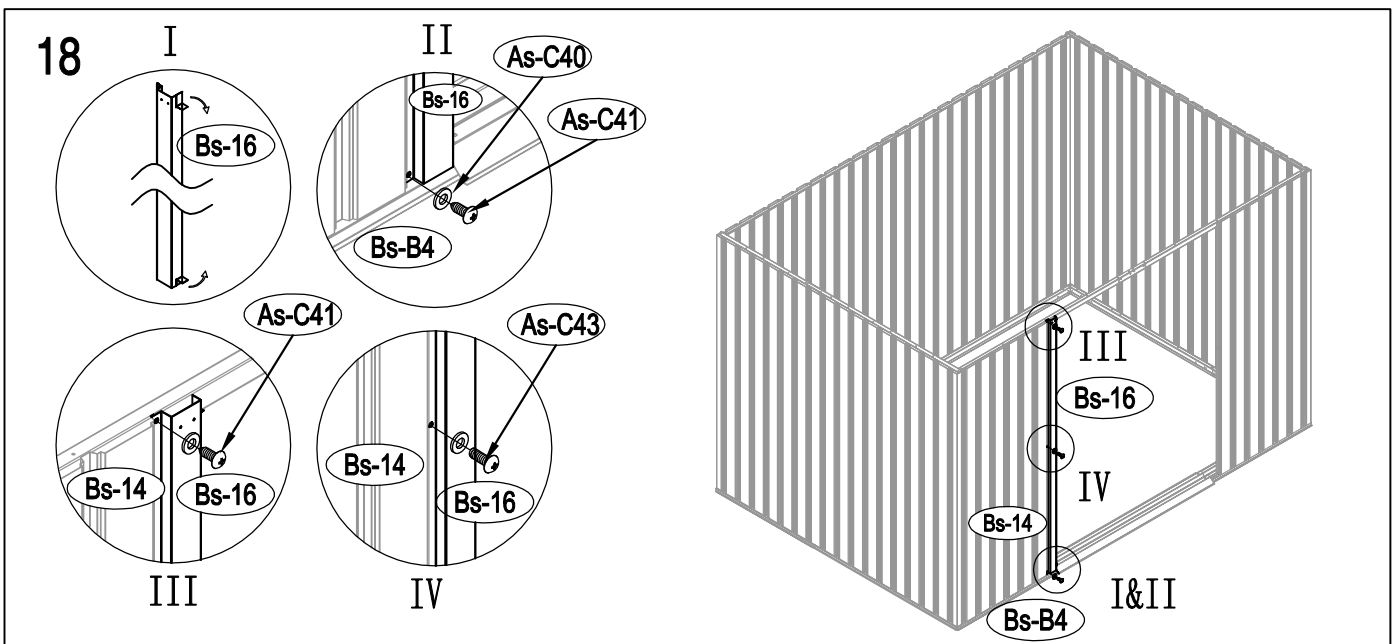
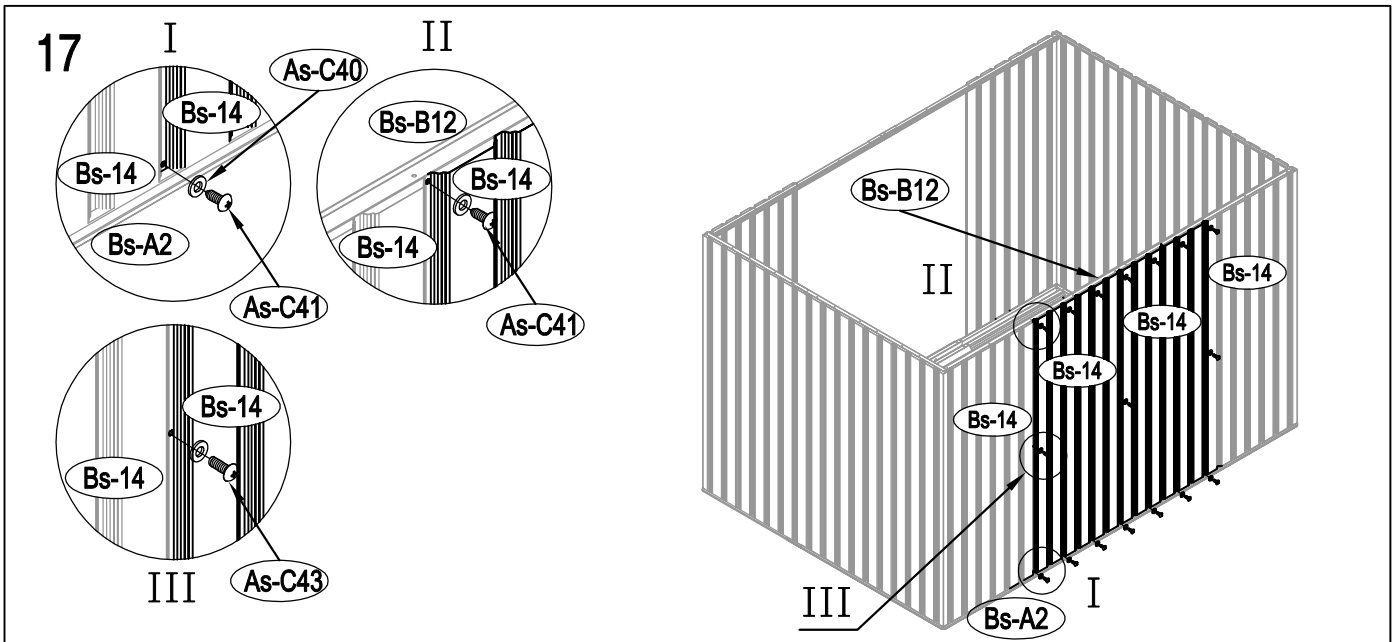
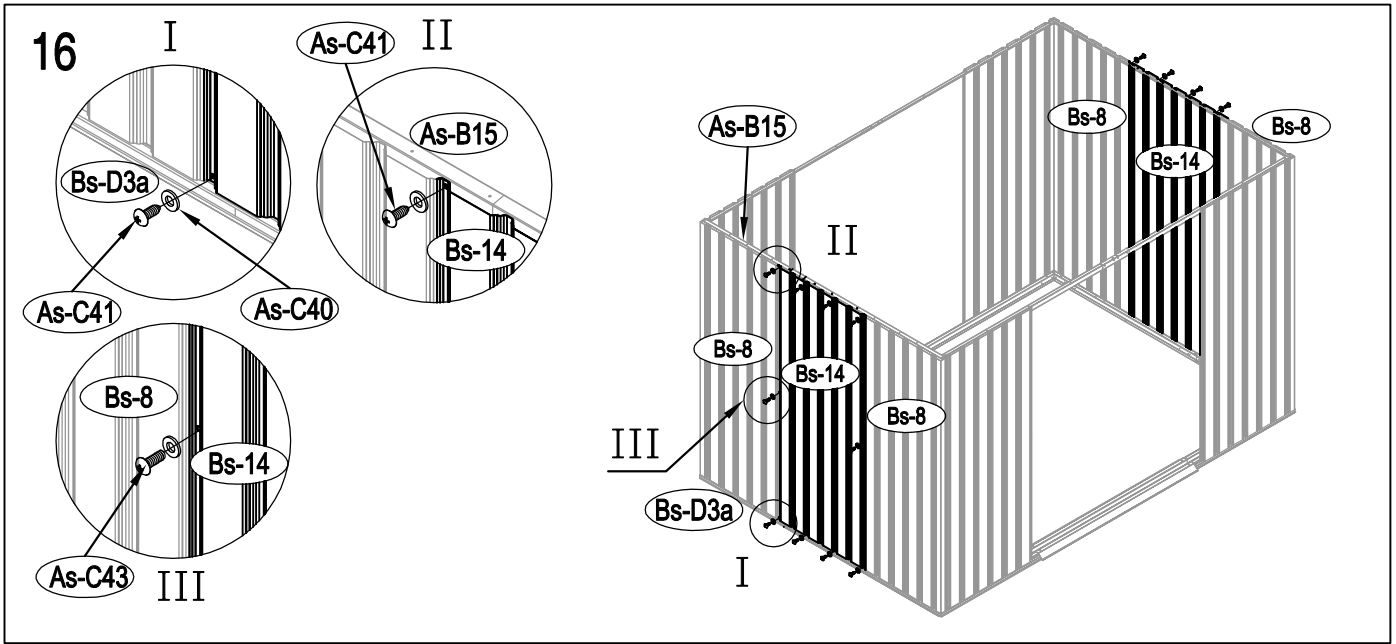

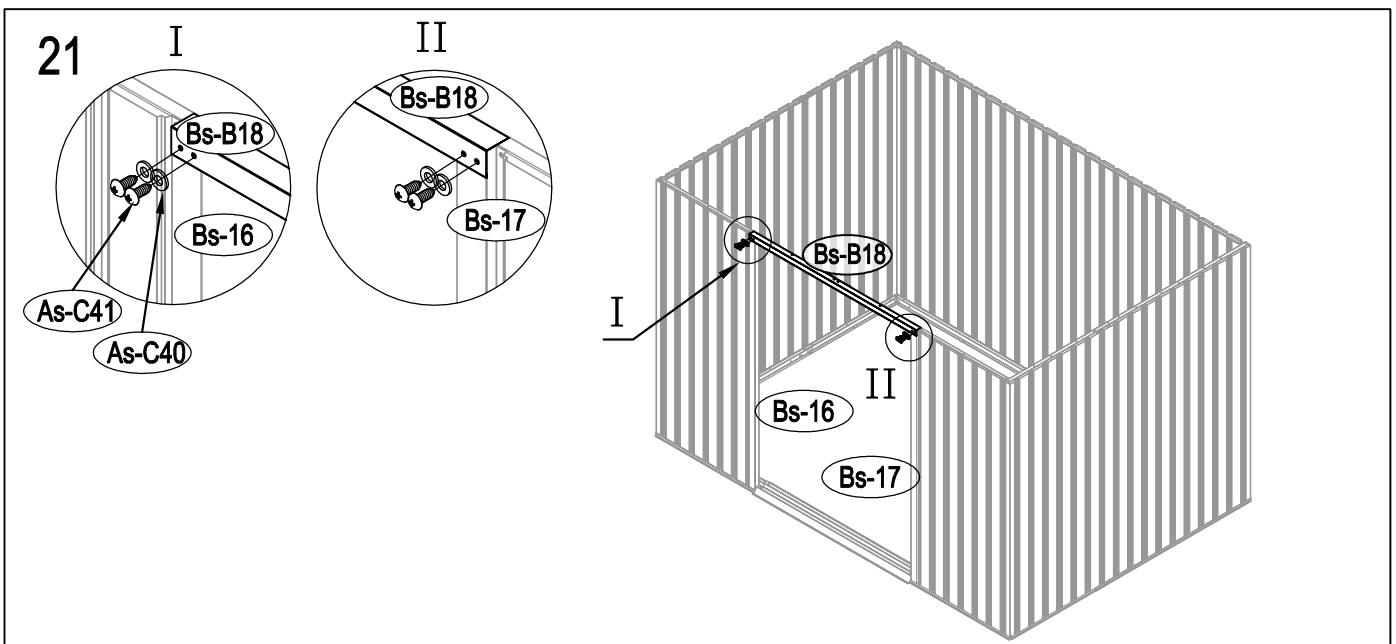
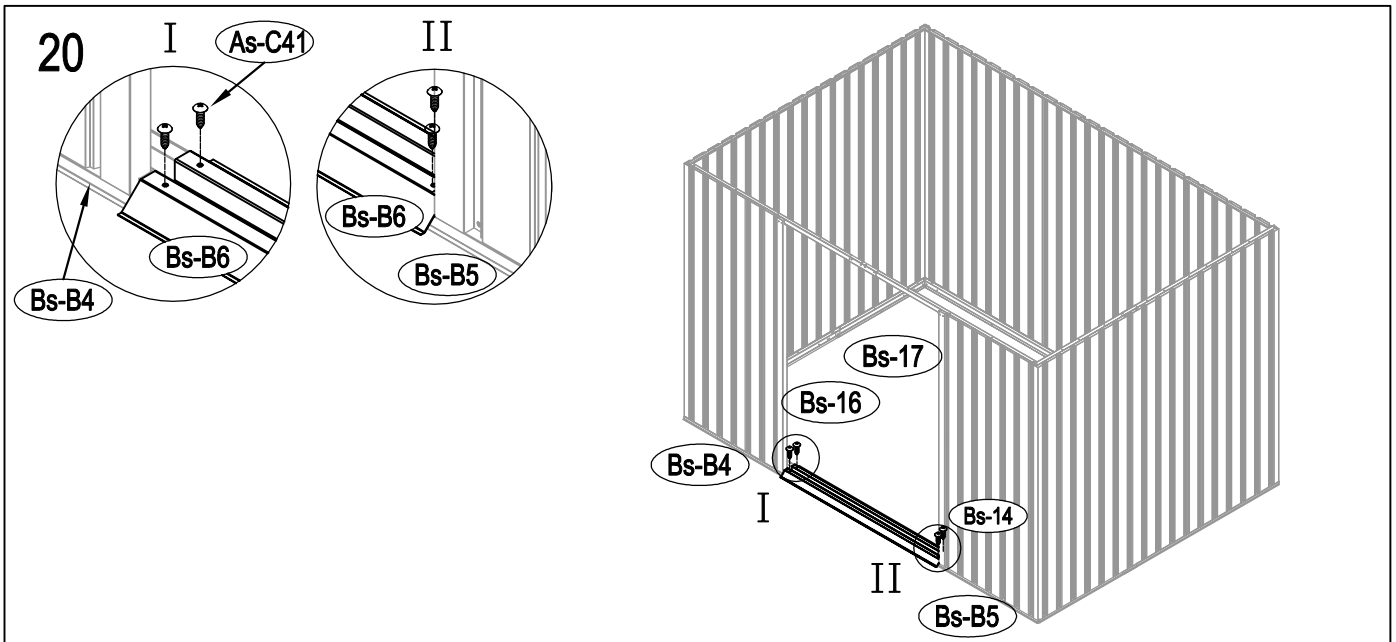
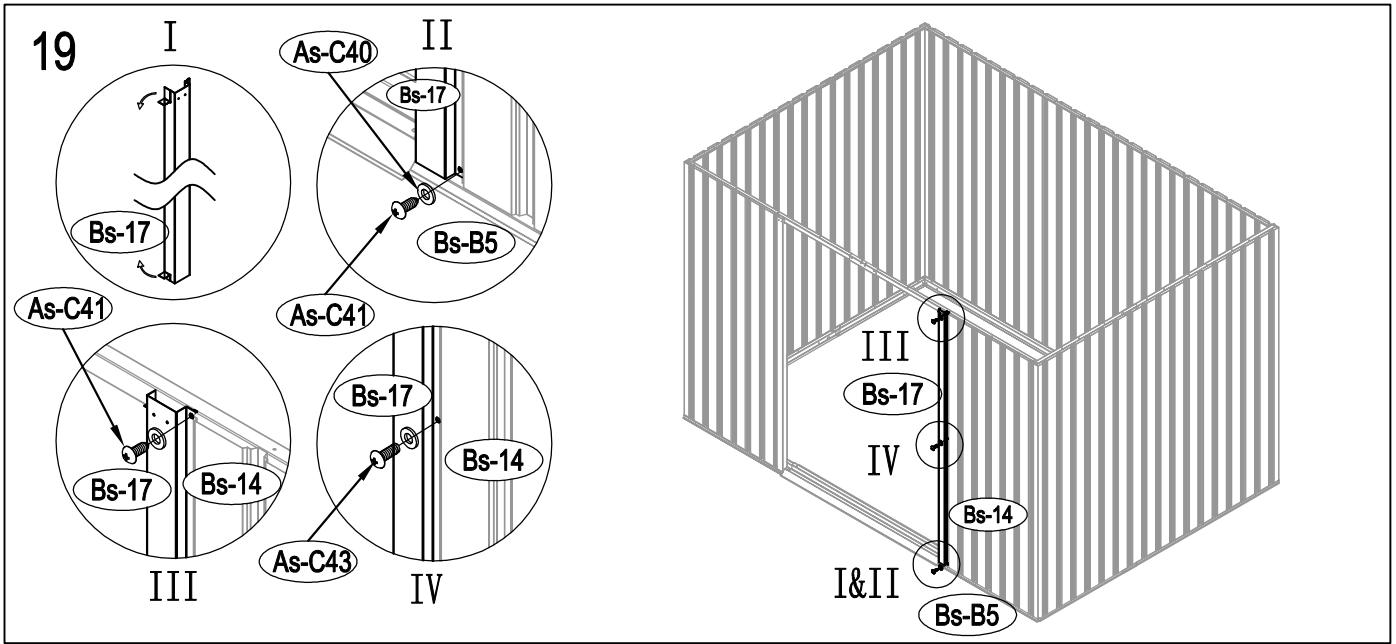

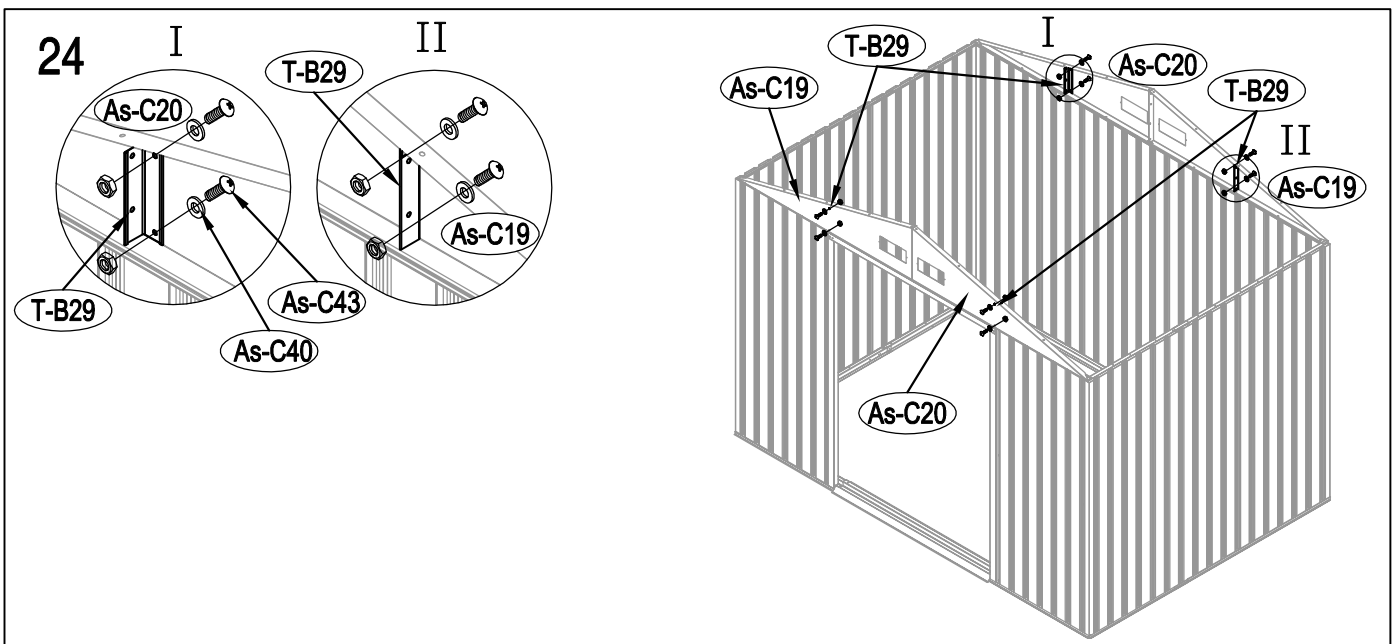
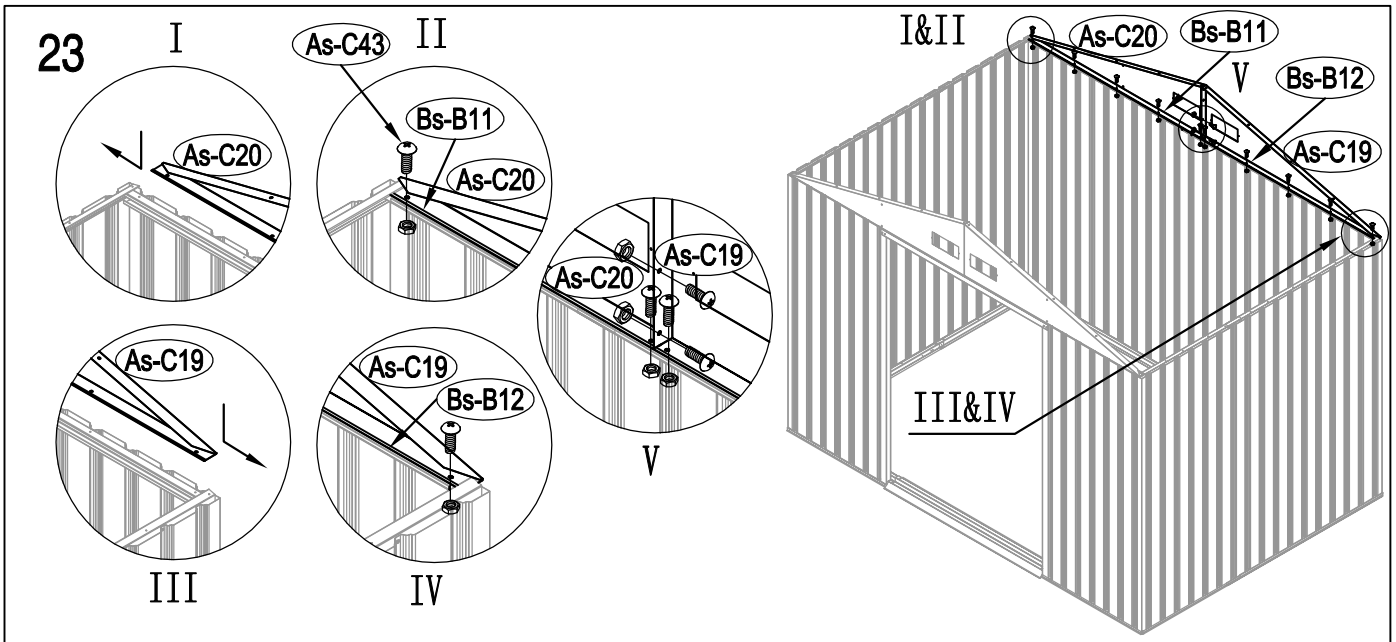
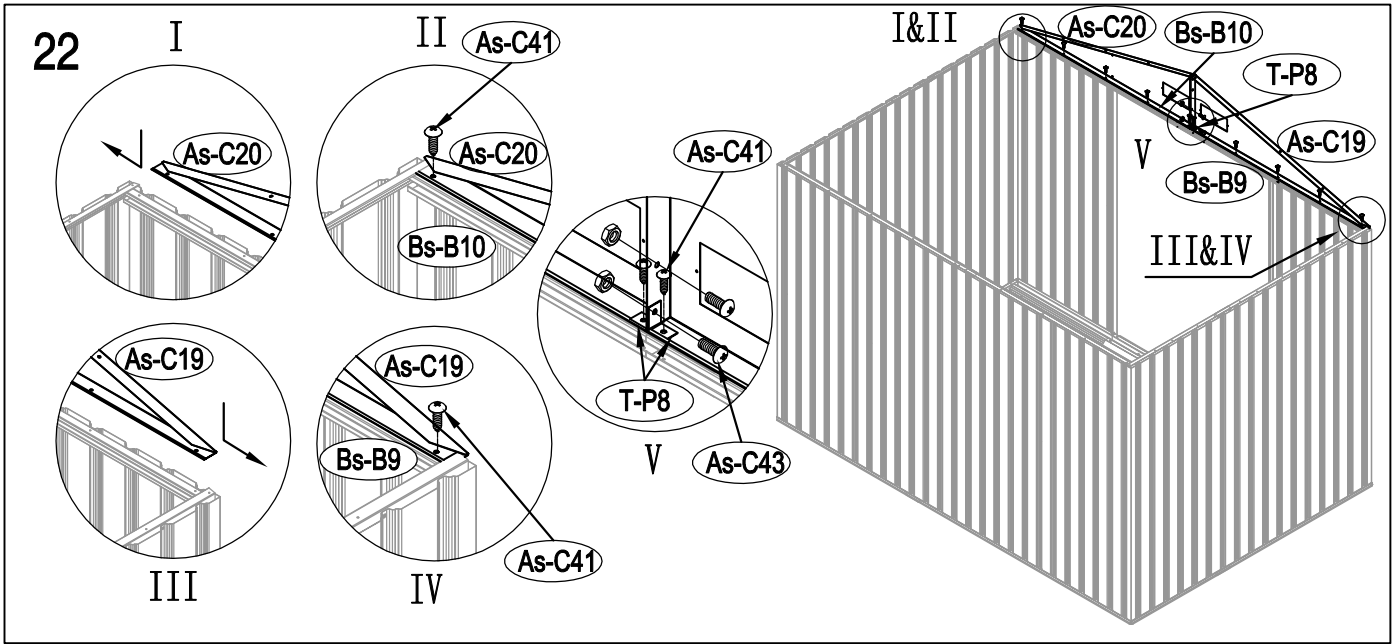

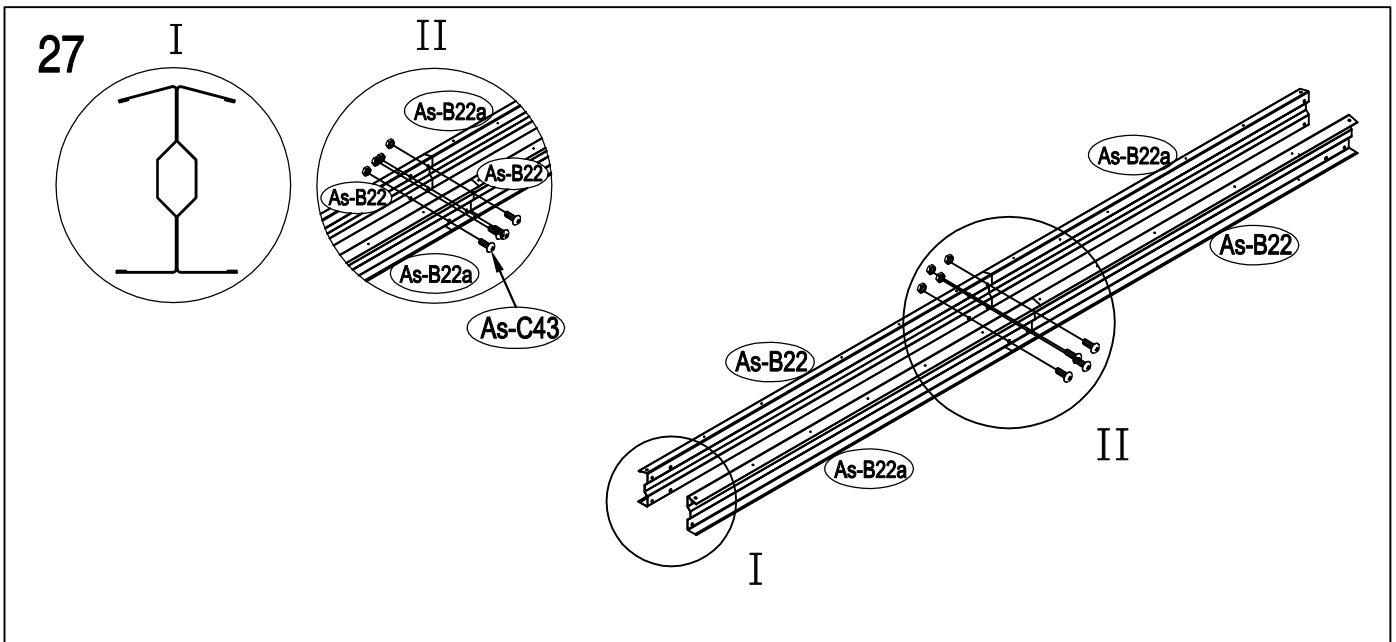
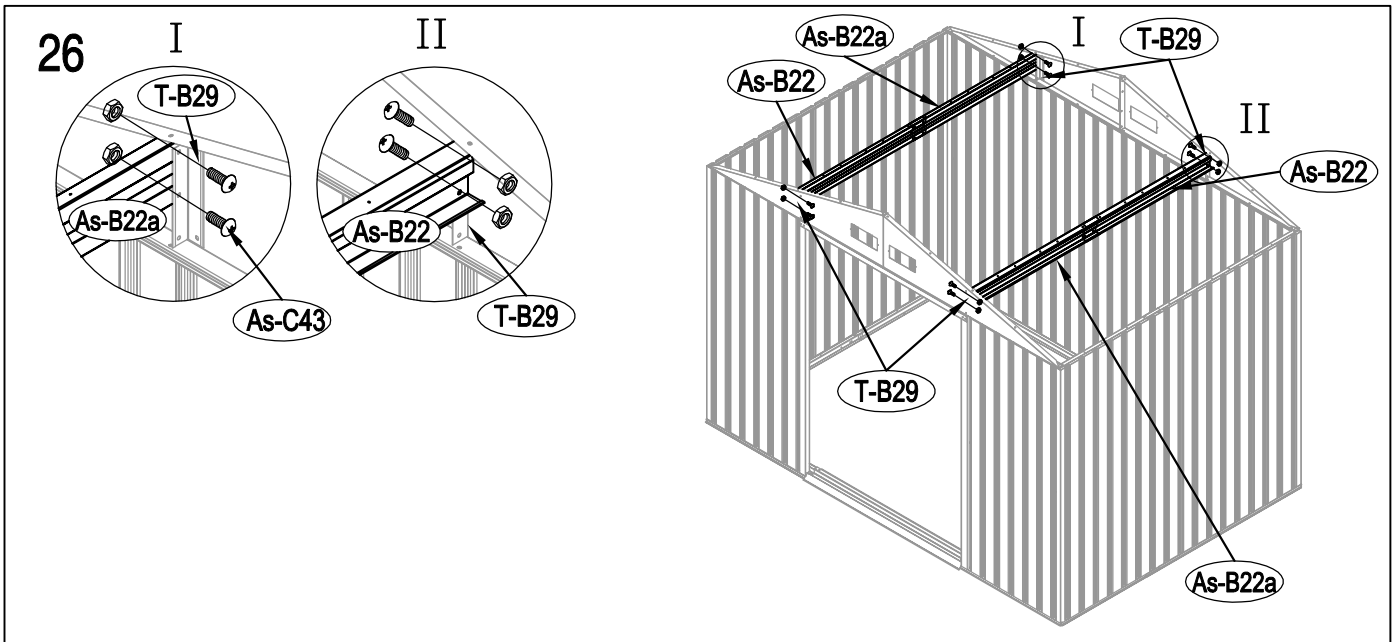
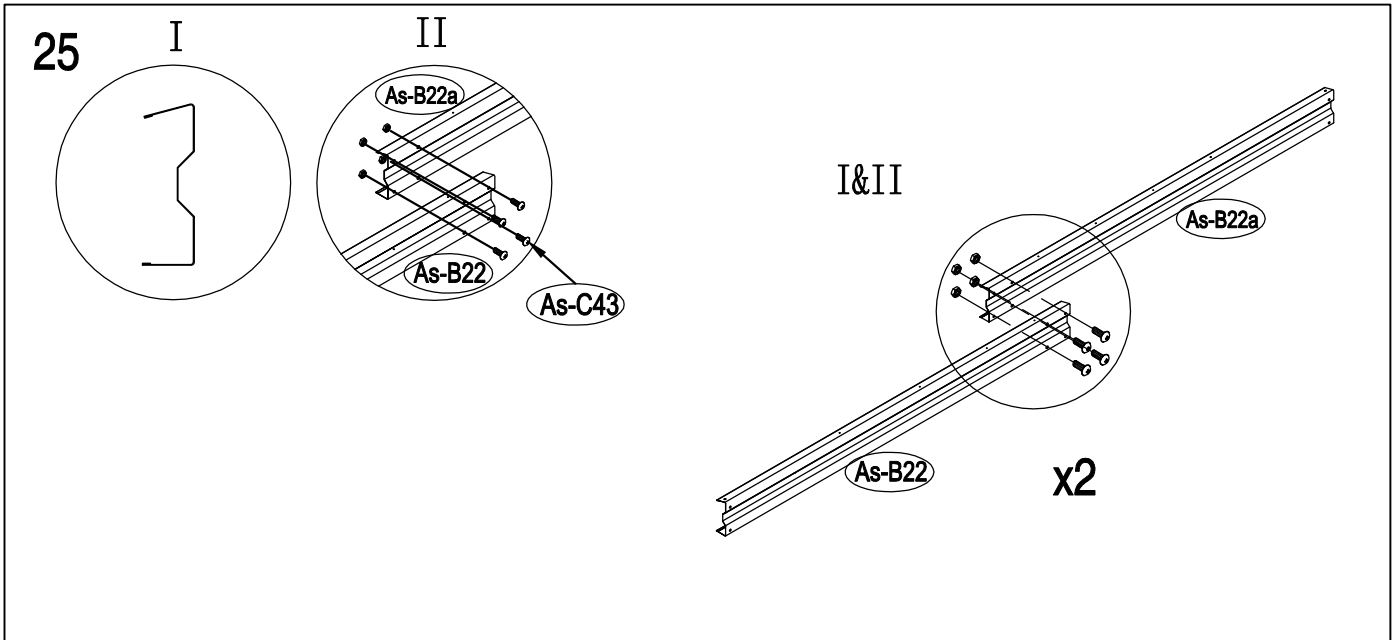

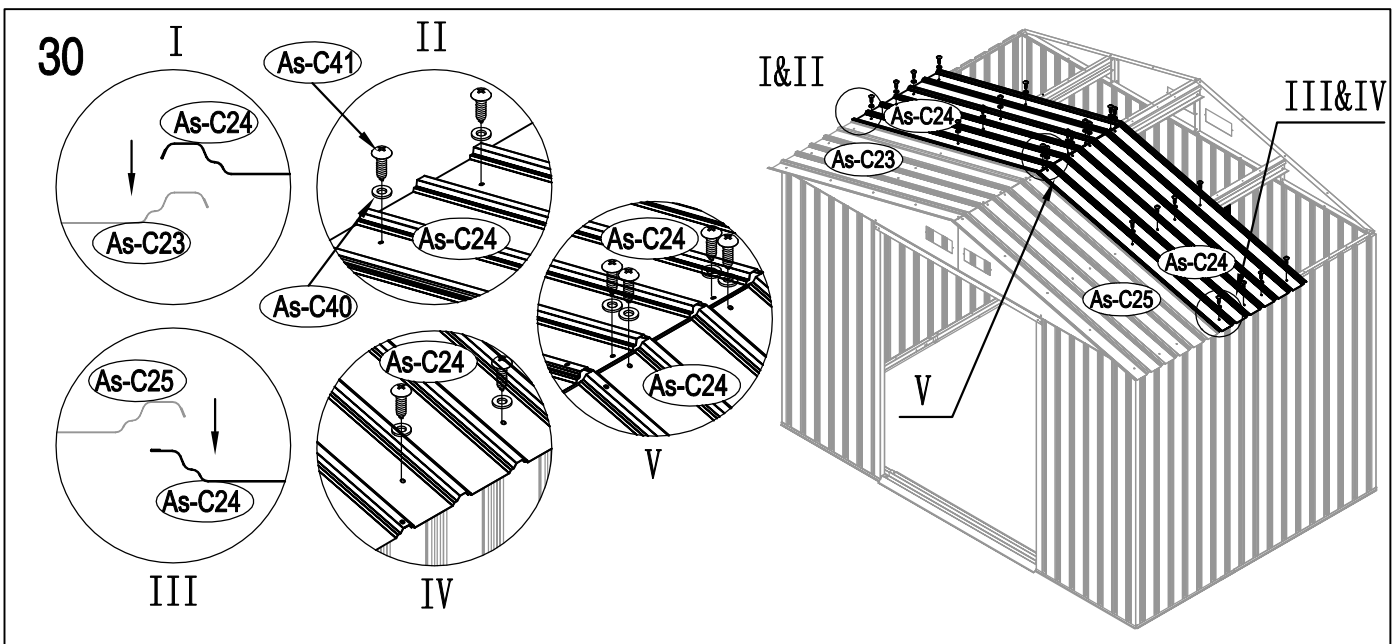
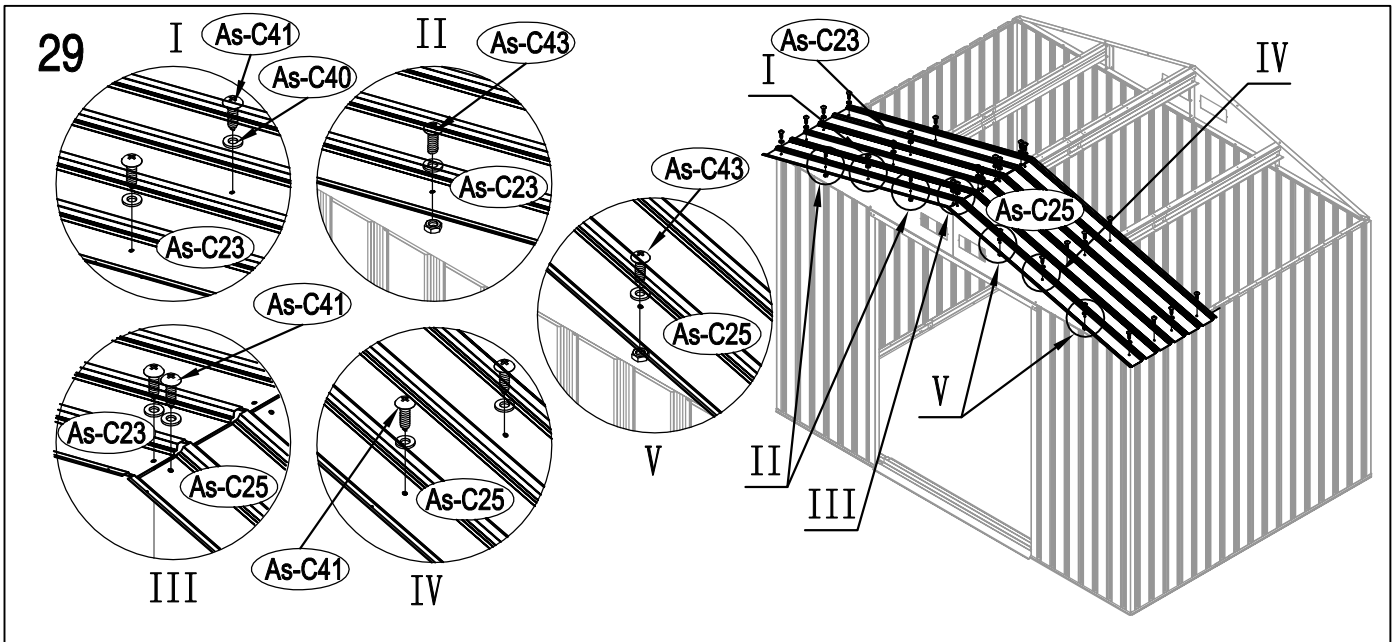
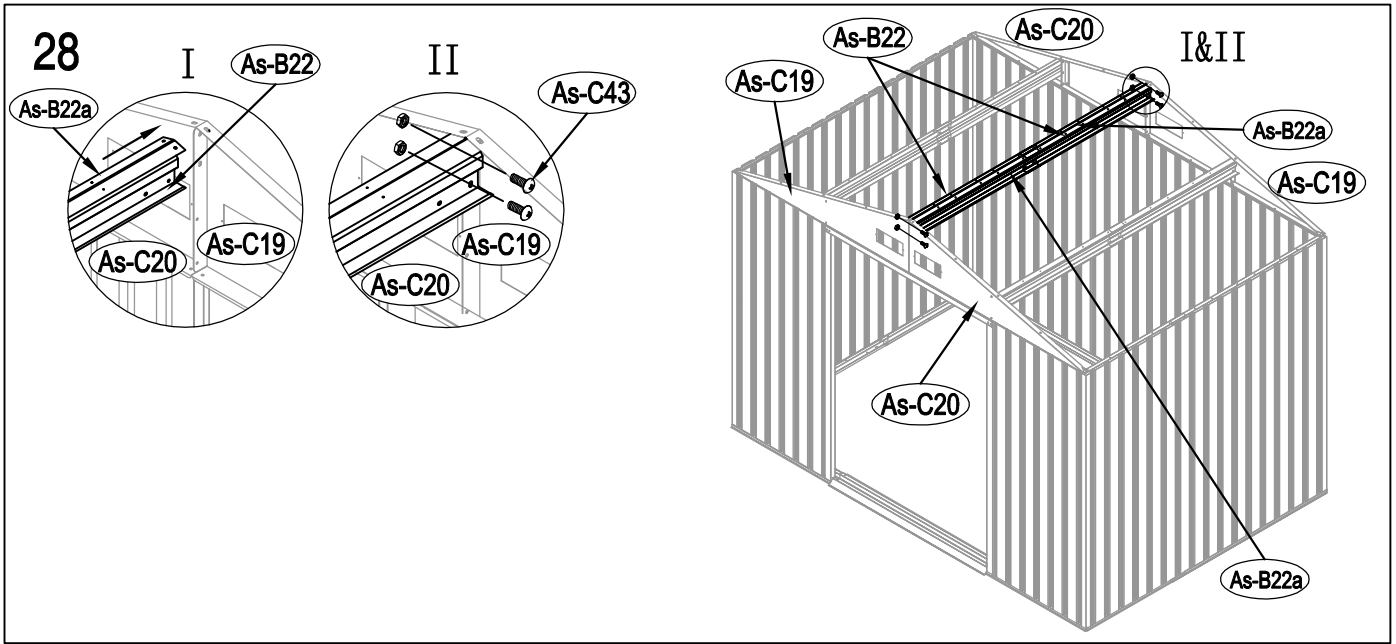

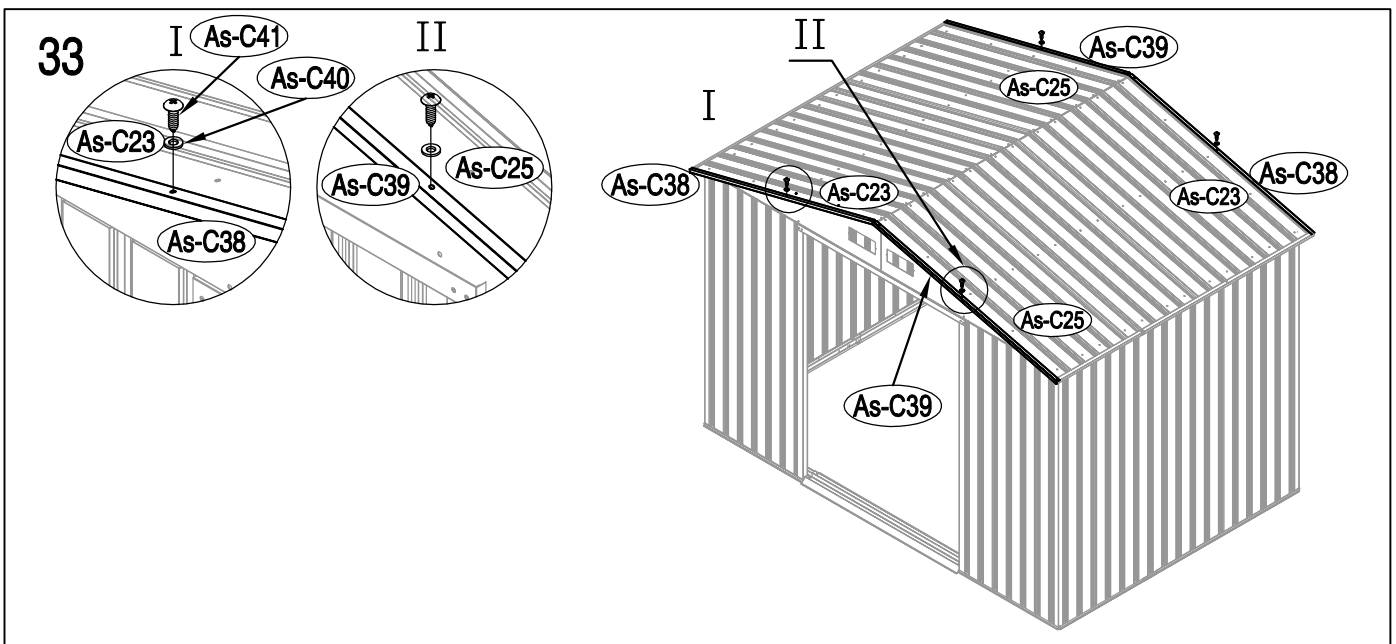
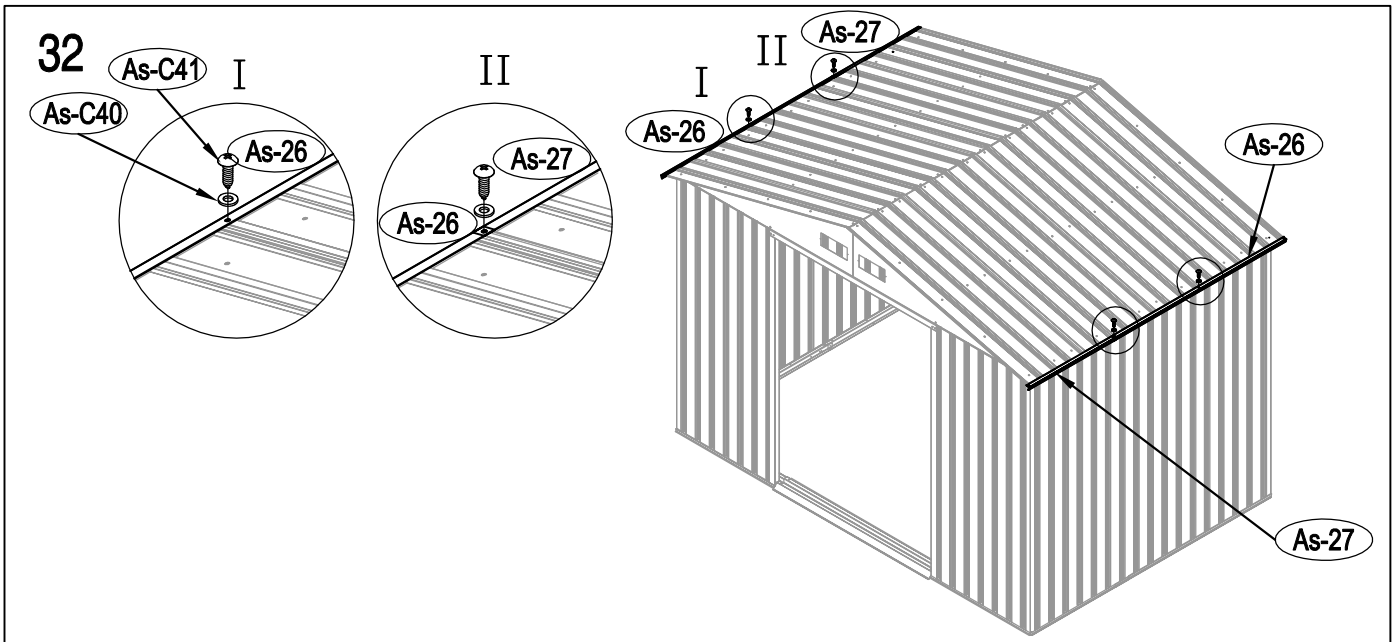
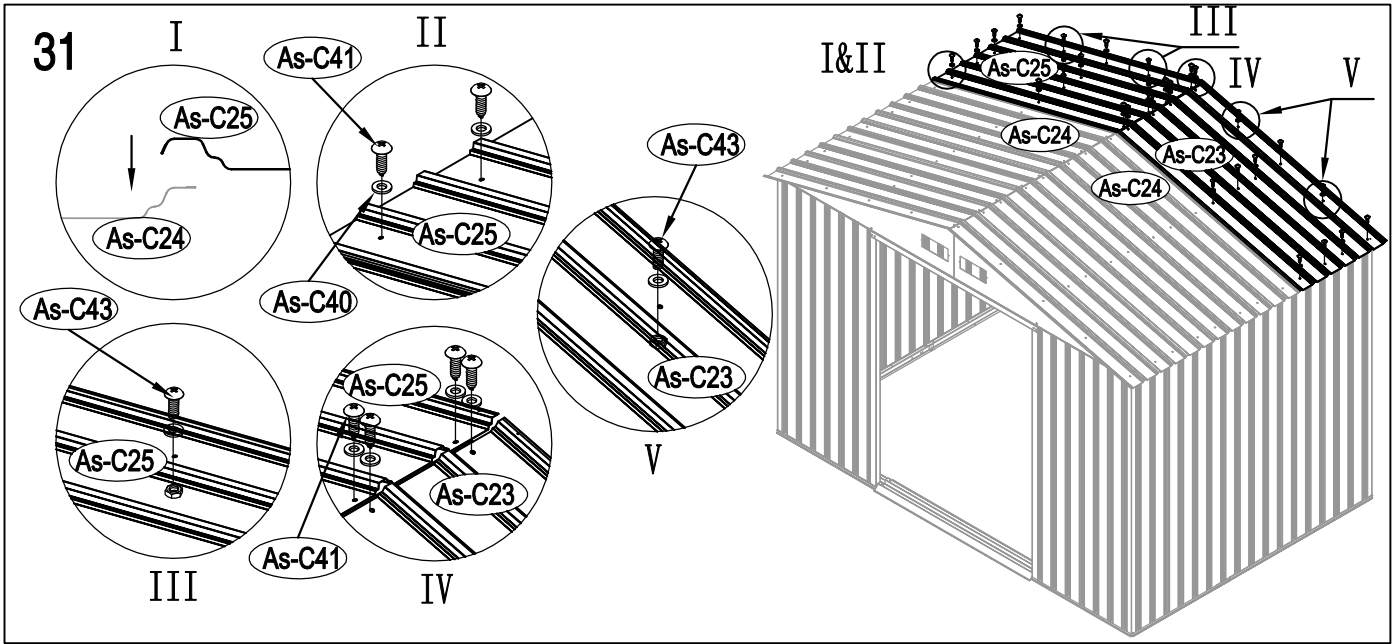

34

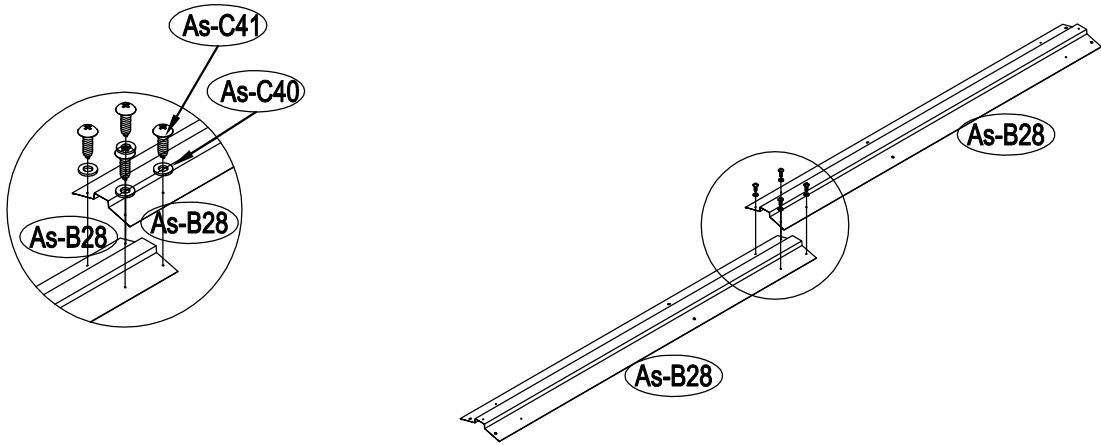

35

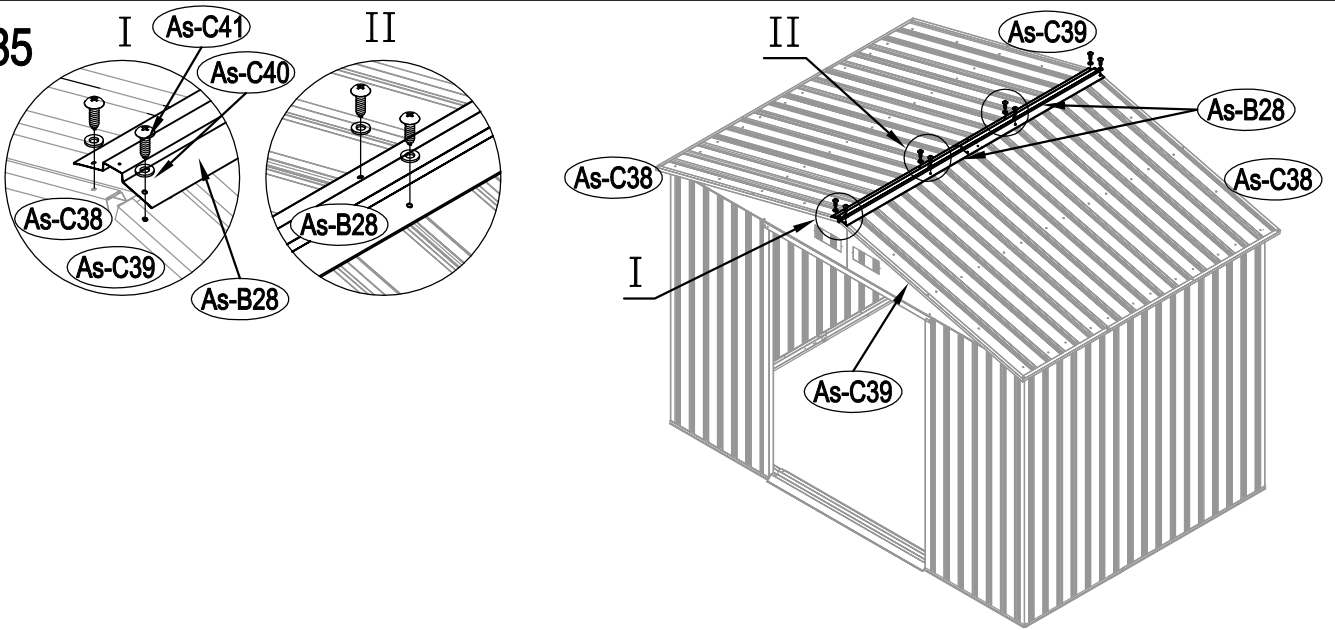

36

